

Hose Barb Sizes



Exhaust Hose Barb
3/8 in I.D. Buna-N Hose



Air Inlet Push-To-Connect
1/4 in O.D. Tubing



Fluid Discharge Hose Barb
3/4 in Buna-N Hose

Warning: All tubing or hoses attached to the pump must be secured with an appropriately sized hose clamp.

Additional Info.

When calling for parts or service, please include the serial number of your pump.



The quick-link chain loop is for securing the pump to the restraining cable.

Additional drawings and parts lists can be found at www.DGSI.info

SRX-R PUMPS

Models TR-975
Quick Start Guide V1.2

Unpacking and Preparation

To remove the pump, separate the packing tape and four staples from the sides of the box, then pull apart the two box halves.

IMPORTANT! You will need to first remove the internal packaging before the pump can be used. A tag will be attached to the pump alerting you of this.



To remove the internal packaging:

1. Remove the bottom bolt that secures the screen with either a 1/2 in socket or adjustable wrench.



2. Remove the two bolts from the bottom valve seat using either a 1/2 in socket or adjustable wrench.



3. Remove the bottom valve seat and check-ball.



Internal foam packaging



- Now remove the pump body by simultaneously twisting the valve assembly and pulling at the same time until the pump and the body easily separate.
- Once separated, remove the upper-and-lower protective foam packaging.

Note: This packaging is provided to protect both the float and control rod from damage during shipping. DGSi recommends that you save this packaging as well as the box for any future shipping requirements.

To reassemble the pump, follow the above steps in reverse order. When installing the bottom check-valve, it is recommended that you stand the pump upside-down on the discharge hose-barb, and then tighten the two bolts to pull the O-ring seals into place.

Additional drawings and parts lists can be found at www.DGSi.info

Maintenance

To clean the internal components of the pump, remove the housing as outlined in steps 1 – 4 in Packing and Unpacking, then remove the cotter and clevis pins from the bottom assembly before sliding the "T" assembly from the center discharge tube.



The control rod and float can now be removed for cleaning. Remove the barbed fittings to clean the exhaust and air-inlet valves from any debris.



To reassemble the pump, follow the above steps in reverse order.

Warning: Any further disassembly should be carried out by DGSi.

Note: Some parts listed are sold only as a kit.

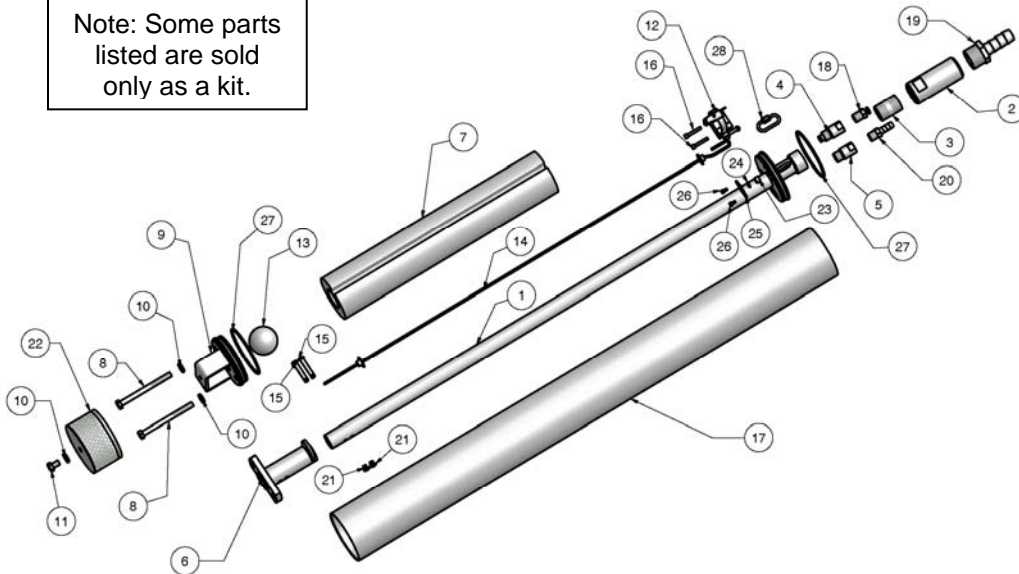

No.	Qty	Part #	Description
1	1	603002	Pump Head Weldment
2	1	603011	Discharge Check Valve Assy.
3	1	603017	Close Nipple 3/4" S.S.
4	1	603012	Air Valve Cartridge
5	1	603026	Exhaust Valve Assembly
6	1	602992	Bottom "T" Assembly
7	1	602874	Float Nitride
8	2	603013	Bolt 5/16" X 3 3/4" Long
9	1	603196	Bottom Valve Seat Weldment
10	3	603022	Sealing Washer 5/16" S.S.
11	1	603014	Bolt 5/16" x 1/2" Long
12	1	603024	Air / Exhaust Valve Assy.
13	1	602013	Ball Buna-n 1.812 Dia.
14	1	603000	Control Rod Stop Assembly
15	2	603020	Pin Clevis 1/4" X 1 7/16" Long S.S.
16	2	603015	Cap Screw 8 X 32 X 1" S.S.
17	1	603040	Pump Body
18	1	2151167	1/4" Tube x 1/4" MNPT Brass
19	1	603176	3/4" Barb x 1" MNPT Brass.
20	1	301040	Brass Hose Barb 3/8 Barb x 1/4" MNPT
21	2	603182	Hairpin Cotter Pin
22	1	603194	Inlet Screen
23	1	601968	Magnet .375" Dia. X .25" Thick Ht
24	1	2404010V	O-Ring, 010 V
25	1	603003	Magnet Cover Plate
26	2	603004	Cap Screw 6 -32 X 1/4" Long
27	2	2404151V	O-Ring, 151 V
28	1	918521	Quick-Link, 5/32" S.S.