

LG-11222 High Load Shear Box

Version 1.0

Operator's Manual

DURHAM GEO-ENTERPRISES

Operating Instructions

© 1997 Durham Geo-Enterprises, Inc.
2175 West Park Court • PO Box 870907
Stone Mountain, GA 30087 USA
Telephone 770.465.7557 • Fax 770.465.7447
Email: garydurham@aol.com
Printed in the USA

Table of Contents

SECTION 1 - SETUP & SYSTEM COMP	3
SECTION 2 - APPLYING NORMAL LOADS	4
SECTION 3 - MEASURING NORMAL LOADS	5
SECTION 4 - LATCHING MECHANISM	6
SECTION 5 - DRAWINGS/BILL OF MAT'LS	7

SECTION 1

Setup & System Components

Upon receiving the unit, please inspect it for damage. If you note any problems, please notify the freight company that delivered the unit and call Durham Geo-Enterprises at ☎ 1-800-837-0864 or fax at 1-770-465-7447.

After unpacking the unit, place the Shear box unit on a sturdy, level surface with access to 100 psi (690 kPa) air service and the appropriate AC supply voltage.

NOTICE: Due to the weight of a full soil box, it is important to leave clear access to both sides of the Shear Box for safe handling.

Prior to running a test, familiarize yourself with making the connection between the Shear Box and the drive unit. This process is fairly simple, but you may find it beneficial to run through the process with an empty soil box the first time.

You should have received a Shear box, with a cross bridge for high loads, and a box that includes the hydraulic pump, reservoir tank, etc. The hydraulic hoses need to be attached to the cylinder, and the electronics need to be attached to the digital indicator. See the Hydraulic/Wiring Diagram for these connections.

If more hydraulic oil is needed, contact Durham Geo or use SPX Corporation's No. 9637 Hydraulic Oil (or similar).

SECTION 2

Applying Normal Loads

The high load bridge has a hydraulic cylinder mounted to it as the loading mechanism. The unit is designed to operate at a maximum of 80 psi of dry air. The pressure applied to the hydraulic system is controlled with a pressure regulator, which is permanently mounted to the system.

Prior to applying any load to the system, check to ensure that the sample box is secure, and that all four hinge pins are in place. At full pressure, there is over 22,000 lbf of load on the sample box. All clamps and pins must be in place and secure.

Normal loads are applied to the sample in the following way:

1. Attach an airline with a ¼" female quick connect fitting to the hydraulic system. Make sure that the orange switch on the regulator is in the "OFF" position prior to connecting the air supply. If you hear the intensifier pumping when you connect the air line, then you know that it is in the "ON" position. Therefore, change the direction of the orange switch.
2. With the air line installed, slowly turn the valve to the "ON" position.
3. There is a black knob that controls that direction of the loading platen. The platen does not move very fast, so when you turn the system on, you can move the platen up and down a few times to get use to the controls of the system.
4. Once you have control of the system, you can start testing. Carefully, move the load platen in the downward direction. Manually line up the square loading platen as it enters the sample box.

CAUTION: THIS IS A PINCH POINT. BE CAREFUL OF FINGERS.

5. Once the load platen enters the sample box, it will put load on the sample. This load can be read on the digital indicator supplied.
6. To increase the load on the sample, increase your line pressure using the pressure regulator. To decrease the load on the sample, decrease your line pressure.

SECTION 3

Measuring the Normal Load

The sample box measures 12 inches by 12 inches (305 mm by 305 mm). The normal load is measured by using a pressure transducer in the hydraulic line and calibrating it with a digital indicator. The digital indicator converts the line pressure from psi of hydraulic oil to pounds force. This load is automatically displayed on the indicator and can be divided by 144 in² in order to get your pounds per square inch on the sample.

SECTION 4

Latching Mechanism

For safety, when the hydraulic bridge is lifted up to a stop, a latch is automatically engaged. This is to keep the bridge from falling down if bumped or under any unusual circumstances. The latch is located and mounted on the bridge on the pivot side only. To unlatch the mechanism, push open the moving lever arm and lower the bridge.

CAUTION:

For safety reasons, have one person unlatch the mechanism, while another one lowers the bridge.

SECTION 5

Drawings and Bill of Materials

1. Bill of Materials for all of the parts in the High Load Assembly
2. Assembly drawings and location of parts
3. Hydraulic Assembly drawing
4. Wiring Diagram for Digital Indicator and Solenoid Valve

ITEM	QTY	QTY	QTY	QTY	PART NUMBER	DESCRIPTION	VENDOR
1	X				LG-11222	HIGH LOAD HYDRAULIC BRIDGE, SHEAR BOX	
2	1				600270	BRIDGE CROSS PLATE	8 X 17.75 X 3/8" THK 1018 STEEL PLATE
3	2				600273	BRIDGE CROSS BEAM	2X4X1/4" RECTANGULAR STEEL TUBING
4	8				600296	HINGE PLATE	2" X 6" X 1/2" THK 1018 STEEL PLATE
5	4				600297	HINGE BLOCK	1-3/4" SQR 1018 BAR
6	2				600294	INSIDE HINGE BRACKET	6 X 8.25 X 3/8" THK STEEL PLATE
7	2				600295	OUTSIDE HINGE BRACKET	6 X 8.25 X 3/8" THK STEEL PLATE
8	4				600277	HINGE PIN SELF LOCKING	
9	1				600278	CYLINDER ADAPTOR PLATE	1/2" THK ALUMINUM PLATE
10	1				600280	UPPER BALL COUPLING	1.75 DIA STEEL ROD
11	1				600282	1-1/4" DIA STEEL BALL	
12	1				600292	22000 LB SHEAR BOX HYDRAULIC PACKAGE ASSEMBLY	

QTY FOR PART No.	LG-11222	 <p>Durham Geo 2175 West Park CT. Stone Mountain, Ga. 30086</p>					
------------------	----------	--	--	--	--	--	--

TITLE: LG-11222 HIGH LOAD FOR SHEAR BOX	ORIGINATOR: JOM
---	-----------------

DATE: 2/10/00	SHEET 1 OF 4	CADFILE:	BILL OF MATERIAL No. B-LG-11222
---------------	--------------	----------	---------------------------------

ITEM	QTY	QTY	QTY	QTY	PART NUMBER	DESCRIPTION	VENDOR
13	1				600289	3000 PSI PRESSURE TRANSDUCER	
14	1				600290	TRANSDUCER ADAPTOR, 1/4 NPT	
15	1				E-405	DIGITAL READOUT WITH CASE	
16	1				600281	LOWER BALL COUPLING	2" DIA STEEL ROD
17	1				600283	OUTER COUPLING	3" DIA STEEL ROD
18	1				600293	3000 PSI ACCUMULATOR CHARGED TO 2000 PSE	
19	1				600284	BOTTOM PLATEN	1" THK 12 X 12 STEEL PLATE
20	1				600272	PUMP/ACCUMULATOR PLATE	1/4" THICK ALUM PLATE
21	1				600359	DUAL 10 AMP RELAY BOARD	
22	1				205313	PLUG 5 PIN DIN METAL BODY	
23	1				240301	CABLE GLAND 1/4" DIA	
24	7 FT					TRANSDUCER CABLE FOR WIRING	

QTY FOR
PART No.

LG-11222

Durham  **Geo**
 2175 West Park CT. Stone Mountain, Ga. 30086

TITLE:

LG-11222 HIGH LOAD
FOR SHEAR BOX

ORIGINATOR:

JOM

DATE:

2/10/00

SHEET

2

OF

4

CADFILE:

BILL OF MATERIAL No.

B-LG-11222

ITEM	QTY	QTY	QTY	QTY	PART NUMBER	DESCRIPTION	VENDOR
25	4				187629	SEIVE SHAKER FEET	
26	6				600274	PUMP/ACCUM. PLATE STANDOFFS	
27	1				600271	MALE 1/4" IND. QUICK CONNECT, 1/4 NPT	
28	1				2151075	1/4" NPT NIPPLE	
29	3				600275	1/4 NPT MALE-9/16-18 MALE STRAIGHT FITTING	
30	3				600276	12" LONG HYD. HOSE 3000 PSI WITH 9/16-18 FEMALE HYD FITTING	
31	2				600279	1/2 NPT MALE-9/16-18 MALE STRAIGHT FITTING	
32	2				600285	1/2" NPT HEX PLUG	
33	2				600286	3/8 NPT MALE-9/16-18 MALE STRAIGHT FITTING	
34	1				600287	3/4 NPT - 1/2 NPT HEX NIPPLE	
35	2				600288	72" LONG HYD. HOSE 3000 PSI WITH 9/16-18 FEMALE HYD FITTING	
36	2				600335	3/4 NPT MALE-9/16-18 MALE STRAIGHT FITTING	

QTY FOR PART No. LG-11222		
	Durham 2175 West Park CT.	Geo Stone Mountain, Ga. 30086

TITLE:	LG-11222 HIGH LOAD FOR SHEAR BOX	ORIGINATOR: JOM
--------	-------------------------------------	--------------------

DATE: 2/10/00	SHEET 3	OF 4	CADFILE:	BILL OF MATERIAL No. B-LG-11222
------------------	------------	---------	----------	------------------------------------

ITEM	QTY	QTY	QTY	QTY	PART NUMBER	DESCRIPTION	VENDOR
37	1				600349	SOLENOID VALVE	
38	1				600377	CROSS FITTING 4 X 1/4 NPT FEMALE	
39	1				600378	3/8 NPT MALE-9/16-18 MALE STRAIGHT FITTING W/ O-RING	
40	1				600379	1/4 NPT MALE-9/16-18 MALE STRAIGHT FITTING WITH O-RING	
41	1				600380	3/4-16 MALE W/O-RING TO 9/16-18 MALE HYD STRAIGHT FITTING	
42	1					1/2-20 UNF 1-1/2 LNG STUD	
43	4					1/4" DIA SPRING PIN, 1-1/2" LONG	
44	1					#8-32 UNC SET SCREW	
45	4					5/8-18 UNF HEX NUTS	
46	10					5/8" LOCK WASHER	
47	42					5/16"-18 UNC 3/4" LONG FLAT HEAD CAP SCREW	
48	6					5/8-18 UNF HEX HEAD BOLT 1-3/4" LONG	

QTY FOR
PART No.

LG-11222

Durham



Geo

2175 West Park CT.

Stone Mountain, Ga. 30086

TITLE:

LG-11222 HIGH LOAD
FOR SHEAR BOX

ORIGINATOR:

JOM

DATE:

2/10/00

SHEET

4

OF

4

CADFILE:

BILL OF MATERIAL No.

B-LG-11222

PART NUMBER
ASSEMBLY A

REV.
A

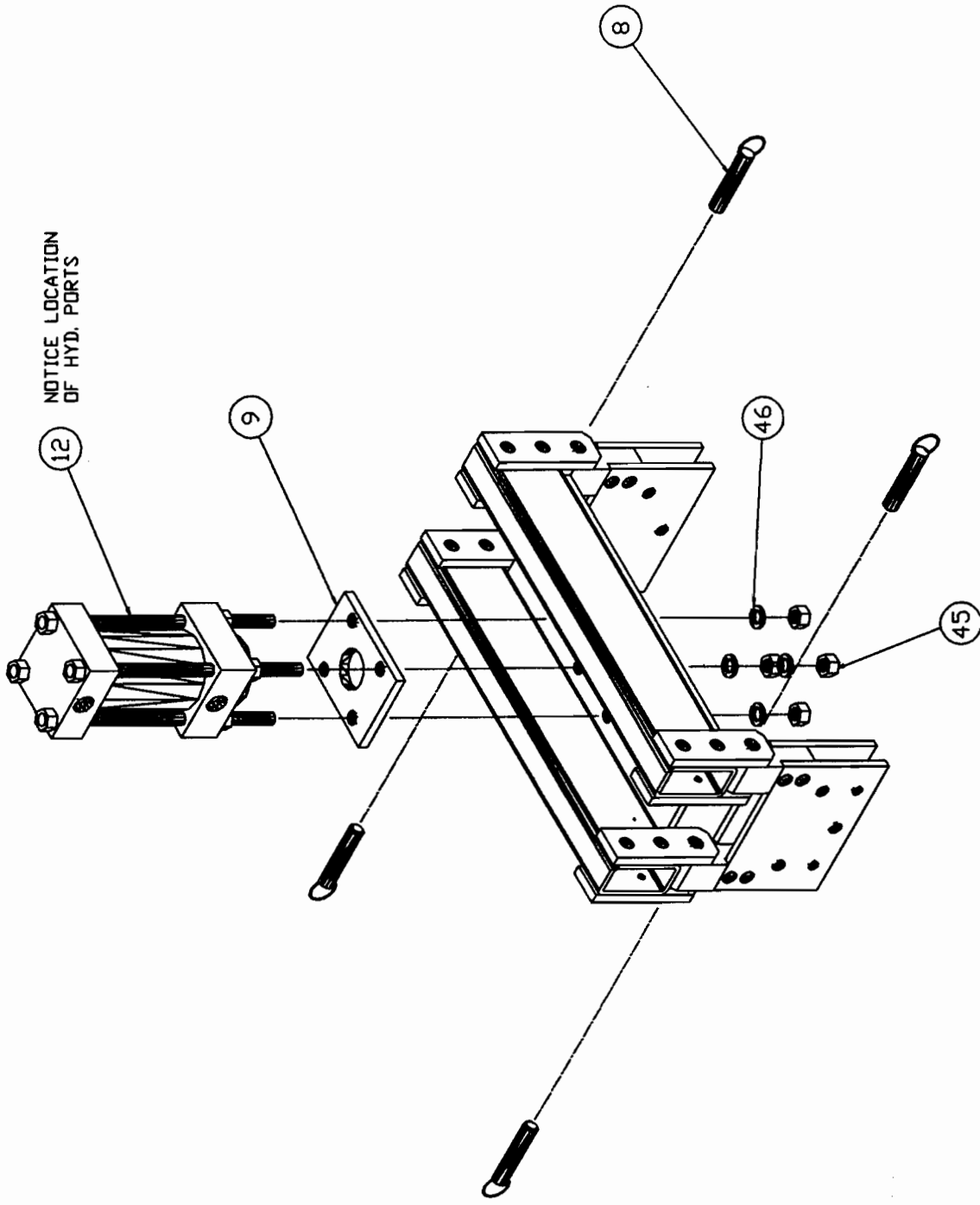

NOTICE LOCATION
OF HYD. PORTS

		2175 West Park Ct. Stone Mountain, Ga. 30087	
DATE:	8/28/70	SHEET OF:	3 4
DESIGNED BY:	BY/DM	SCALE:	C
CHECKED BY:	BY/DM	APPROVED BY:	
TOLERANCES UNLESS OTHERWISE SPECIFIED:			
DECIMAL:	.X ± .020		
	.XX ± .010		
	.XXX ± .004		
FRACTIONAL:	± 1/32		
ANGULAR:	± 1/8°		
RADIUS:	± 1/32		

DATE	BY	REVISION NUMBER	DATE	BY	REVISION NUMBER	DATE	BY	REVISION NUMBER

TITLE:
HIGH LOAD ASSEMBLY INSTR.

DRAWING NUMBER
LG-11222

SHEAR BOX

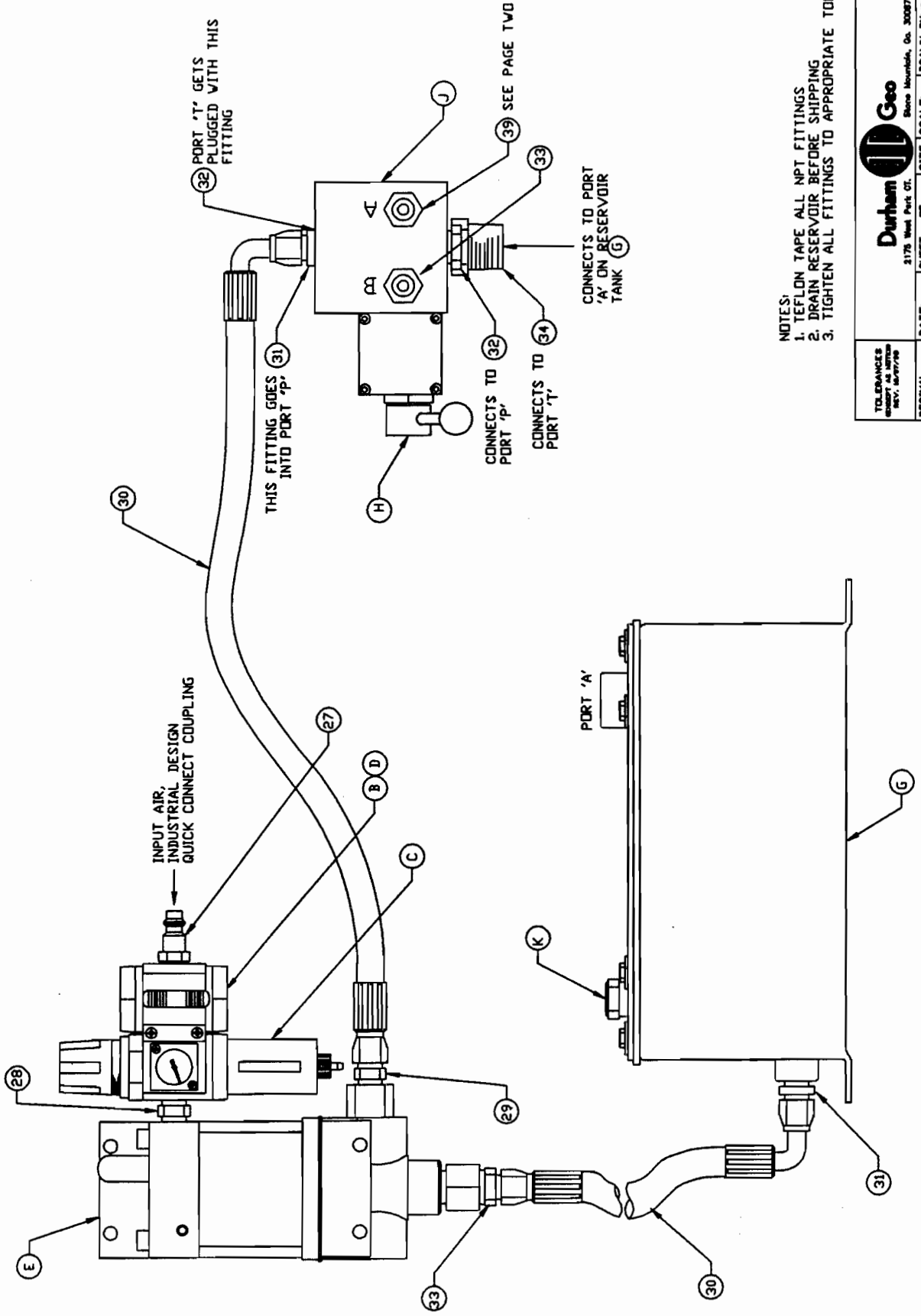

NOTES:
 1. TEFLON TAPE ALL NPT FITTINGS
 2. DRAIN RESERVOIR BEFORE SHIPPING
 3. TIGHTEN ALL FITTINGS TO APPROPRIATE TORQUE

		2176 West Park Ct. Stone Mountain, Ga. 30087	
TOLERANCES UNLESS NOTED OTHERWISE	DATE: 11/21/99	SHEET OF: 1 3	SIZE: C
EXCEPT AS NOTED	REV: 10/27/98	DRAWN BY: JON	
DECIMAL: .X 2 .030 .XX 2 .010 .XXX 2 .004	TITLE: HYDRAULIC/WIRING DIAGRAM	APPROVED BY:	
FRACTIONAL: 3/16	ANGULAR: 1/2°	DRAWING NUMBER	
RADIUS: 1/2"	LG-11222, HIGH LOAD SHEAR BOX		

DATE	BY	CODE	REVISION	REASON

PART NUMBER REV. A

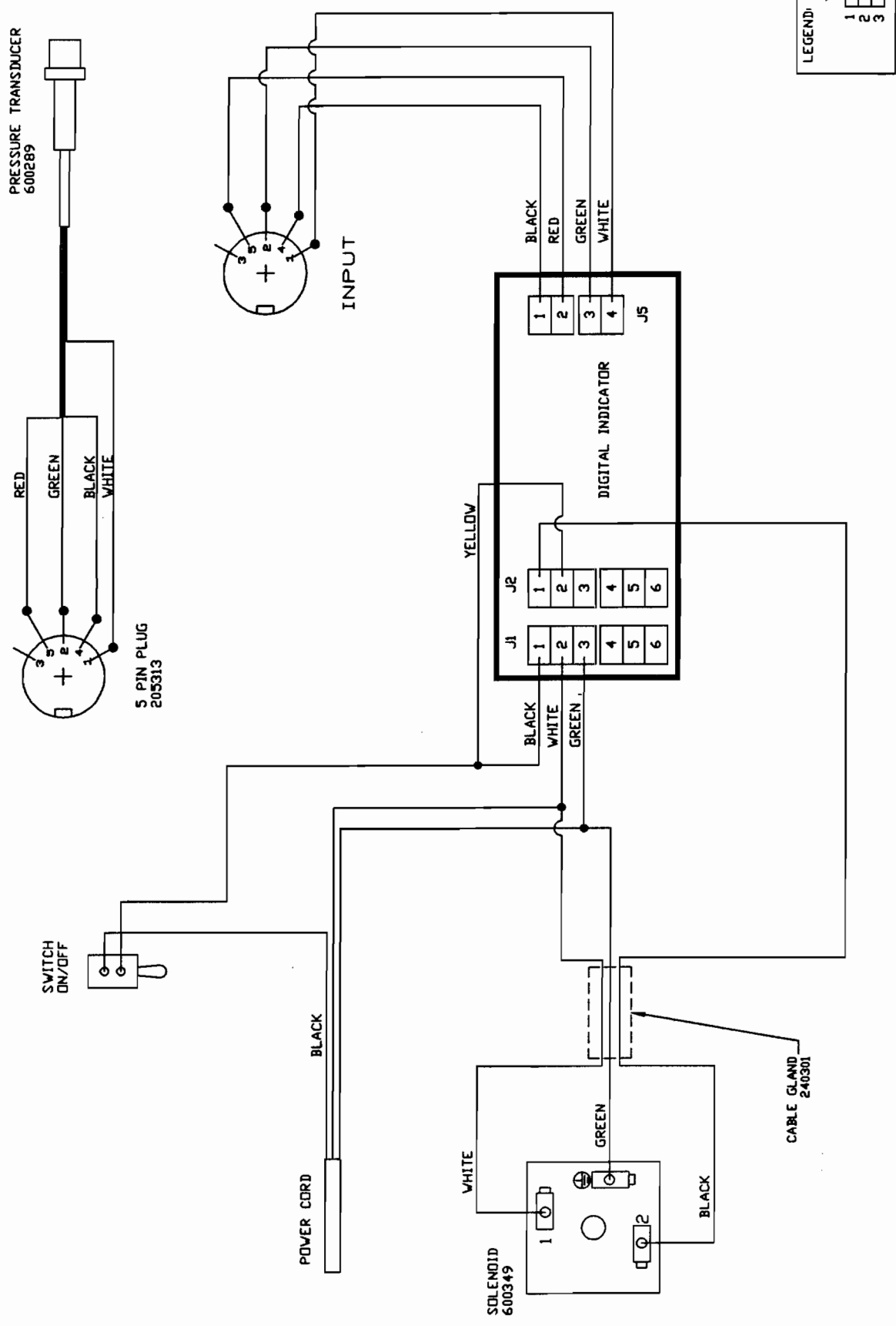

LEGEND: J2
 1 N/D
 2 N/C
 3 COM

Durham Geo
 2175 West Park Ct.
 Stone Mountain, Ga. 30087

TOLERANCES UNLESS SPECIFIED:
 DECIMAL: .X & .020
 .XX & .010
 .XXX & .004
 FRACTIONAL: 1/32
 ANGULAR: 1/8°
 RADIUS: 1/32

DATE: 10/21/99
 SHEET OF: 3
 SIZE: C
 SCALE: 1:1
 DRAWN BY: JGH
 APPROVED BY:

TITLE: HYDRAULIC/WIRING DIAGRAM
 DRAWDING NUMBER: LG-11222, HIGH LOAD SHEAR BOX

DATE	BY	REVISION	DATE	BY	REVISION

REVISIONS FOR PRODUCTION

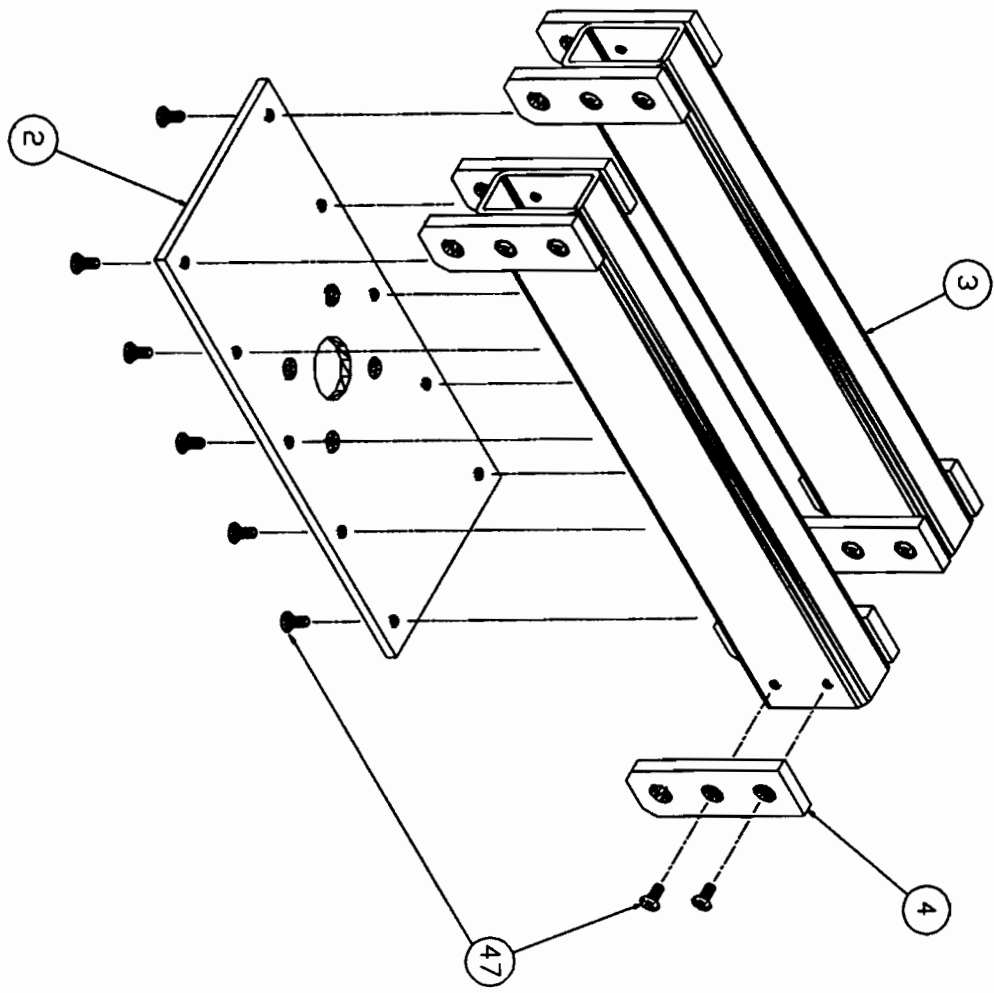

DATE	BY	CODE	REV.	REVISION NUMBER	DATE	BY	CODE	REV.	REVISION NUMBER

TOLERANCES DECIMAL AS SHOWN FRACTIONAL AS SHOWN		DATE: 2/24/00	
DECIMAL: .000, .001, .002, .003, .004, .005, .006, .007, .008, .009, .010, .015, .020, .030, .040, .050, .060, .070, .080, .090, .100, .125, .150, .175, .200, .250, .300, .375, .400, .500, .600, .750, .800, .900, 1.000, 1.250, 1.500, 1.750, 2.000, 2.500, 3.000, 3.750, 4.000, 5.000, 6.000, 7.500, 8.000, 9.000, 10.000		SHEET: 1 OF 4	
FRACTIONAL: 1/32, 1/16, 1/8, 3/16, 1/4, 3/8, 1/2, 5/8, 3/4, 7/8, 1, 1 1/8, 1 1/4, 1 1/2, 1 3/4, 2, 2 1/4, 2 1/2, 2 3/4, 3, 3 1/4, 3 1/2, 3 3/4, 4, 4 1/4, 4 1/2, 4 3/4, 5, 5 1/4, 5 1/2, 5 3/4, 6, 6 1/4, 6 1/2, 6 3/4, 7, 7 1/4, 7 1/2, 7 3/4, 8, 8 1/4, 8 1/2, 8 3/4, 9, 9 1/4, 9 1/2, 9 3/4, 10		SIZE: C	
SCALE:		DRIVEN BY: JDM	
APPROVED BY:		TITLE: HIGH LOAD ASSEMBLY INSTR.	
MANUFACTURE:		DRAWING NUMBER: LG-11222	
DATE: 2/24/00		SHEET: 1 OF 4	
SIZE: C		DRIVEN BY: JDM	
SCALE:		APPROVED BY:	
DRIVEN BY: JDM		TITLE: HIGH LOAD ASSEMBLY INSTR.	
APPROVED BY:		DRAWING NUMBER: LG-11222	
MANUFACTURE:		DATE: 2/24/00	



2175 WIND PAK CT.
 BETHLEHEM, PA. 18017

SHEAR BOX

LG-11222