

VW Arc-Weldable Strain Gauge

52640399

Copyright ©2009 Durham Geo-Enterprises. All Rights Reserved.

This equipment should be installed, maintained, and operated by technically qualified personnel. Any errors or omissions in data, or the interpretation of data, are not the responsibility of Durham Geo-Enterprises. The information herein is subject to change without notification.

This document contains information that is proprietary to Durham Geo-Enterprises and is subject to return upon request. It is transmitted for the sole purpose of aiding the transaction of business between Durham Geo-Enterprises and the recipient. All information, data, designs, and drawings contained herein are proprietary to and the property of Durham Geo-Enterprises, and may not be reproduced or copied in any form, by photocopy or any other means, including disclosure to outside parties, directly or indirectly, without permission in writing from Durham Geo-Enterprises.

SLOPE INDICATOR

12123 Harbour Reach Drive
Mukilteo, Washington, USA, 98275
Tel: 425-493-6200 Fax: 425-493-6250
E-mail: solutions@slope.com
Website: www.slopeindicator.com

Contents

Introduction	1
Installation.....	2
Taking Readings.....	7
Data Reduction	10

Introduction

Applications

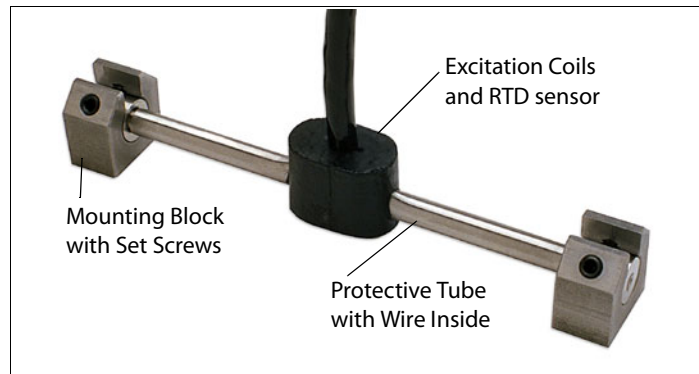

VW Arc-Weldable Strain Gauges are used to measure strain in steel. Typical applications include:

- Monitoring structural members of buildings and bridges during and after construction.
- Determining changes in load on wall anchors and other post-tensioned support systems.
- Monitoring load in struts used to brace excavations.
- Measuring strain in tunnel linings and supports.
- Monitoring areas of concentrated stress in pipes.
- Monitoring distribution of load in pile tests.

Operation

A steel wire is held in tension between two mounting blocks that are welded to the surface of the measured member. Strain in the member is transmitted through the mounting blocks to the wire inside. An increase in tensile strain increases tension in the wire. A decrease in tensile strain decreases tension in the wire.

The tension in the wire is measured by plucking the wire with electromagnetic coils and measuring the frequency of the resulting vibration. Strain in the wire is calculated by squaring the frequency reading and multiplying by a gauge factor and a batch calibration factor.

Installation of the Strain Gauge

- Testing** Test each sensor before installing it. Use a readout and an ohm meter to conduct these tests.
- Connect a readout (see manual readout instructions). Pull, but do not twist, gently on the ends of the gauge. The Hz reading should be seen to increase as the ends are pulled and decrease as they are released.
 - The RTD reading should be near ambient temperature.
 - Resistance between the orange/white and orange leads should be about 300 ohms.
 - Resistance between blue/white and blue leads should be about 2k ohms.

General Considerations **Sensor Handling:** Do not twist or pull hard on the ends of the sensor. This may cause non-repairable damage to the sensor.

Sensor Identification: Mark cables before installation so that sensors can be identified after installation.

Cable Strain Relief: Provide strain relief for signal cables.

Strain Gauge Considerations **Orientation** Position the strain gauge so that its long axis is parallel with the axis of loading.

Bending: The strain gauge should be installed along the neutral axis of the structural member when possible. Bending will increase strain on one side of the neutral axis and decrease strain on the opposite side. Axial strain can be isolated from bending strain by installing gauges on opposite sides of the member and averaging the change in strain reported by both gauges.

Irregularities: Avoid installing strain gauges near irregularities in the member or near the ends of the member since readings from these locations may not adequately represent strain in the other portions of the member.

Sunlight: Try to shield gauges from direct sunlight. If the gauge is heated faster than the steel beneath it, it may report changes in strain that are not representative of the steel.

Reuse: Strain gauges can be reused. Keep in mind that set screws bite into the ends of the gauge. When the gauge is reinstalled, it must be rotated slightly to avoid slippage.

Typical Placement

Threadbars Install gauges on opposite sides of the bar.

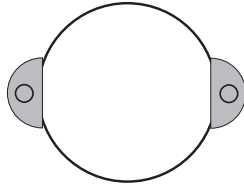

Pipe Piles or Struts Install gauges 120 apart.

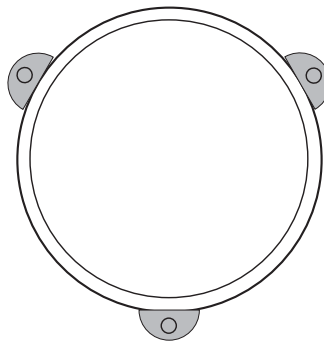

Driven H-Piles Install gauges in the middle of the web. Add protective covering.

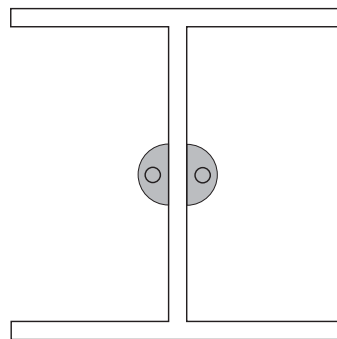

Or

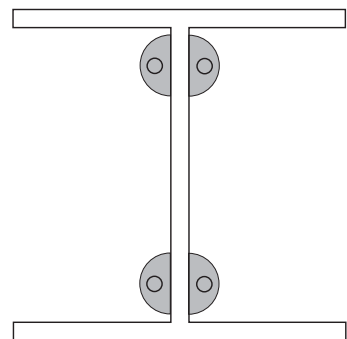

Typical Placement Continued

I-Beams Install gauges in the middle of the web, or if installed on the flanges, as near to the web as possible.

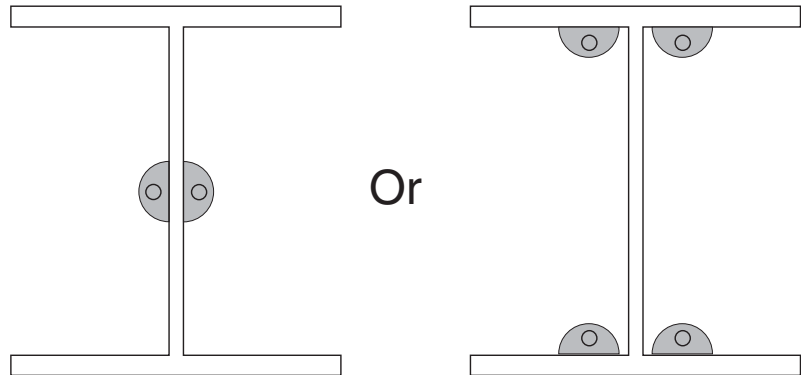

Sheet Piles Install gauges on both sides of the pile, away from the clutches.

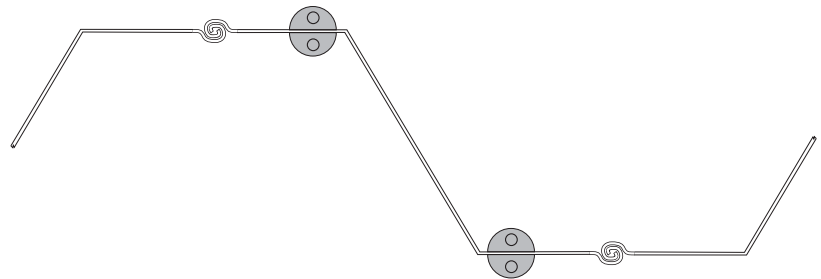

Detailed Instructions

These instructions assume that locations for the strain gauges have already been specified.

Components

The various components of the strain gauge are identified below.

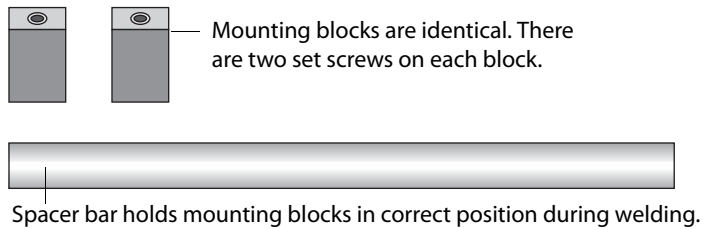
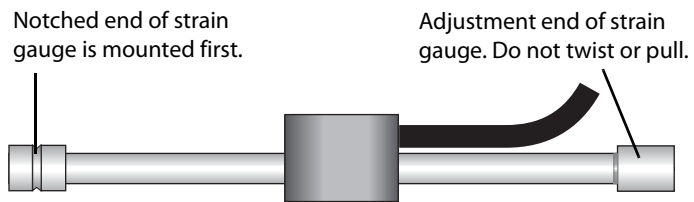

Prepare the Surface

1. Clean the surface with a wire brush or sander to remove all rust and dirt.
2. Use solvent to remove oil and residue.

Prepare Mounting Blocks

It is convenient to have additional spacer bars if you have more than one strain gauge to install.

1. Fit mounting blocks onto spacer bar.
2. Check that ends of spacer bar are flush with outside surface of mounting blocks. Tighten set screws.

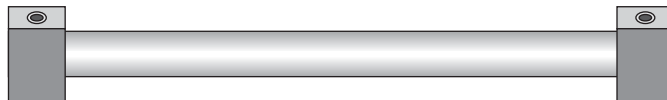

Weld Mounting Blocks

Heat distorts the measured surface, so try to use the lowest power setting on the arc-welder.

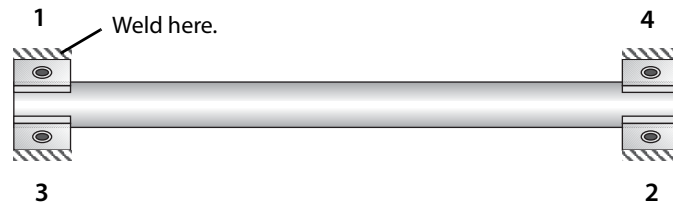

1. Hold mounting blocks against the surface, by pressing firmly on the spacer bar.
2. Weld mounting blocks to the surface. Follow the weld sequence shown above. Do not weld in other areas.
3. Allow welds to cool, then remove spacer bar. If bolt-on protective covers are specified, install studs at least six inches away from the mounting blocks.



Set the Strain Gauge

This step requires a readout.

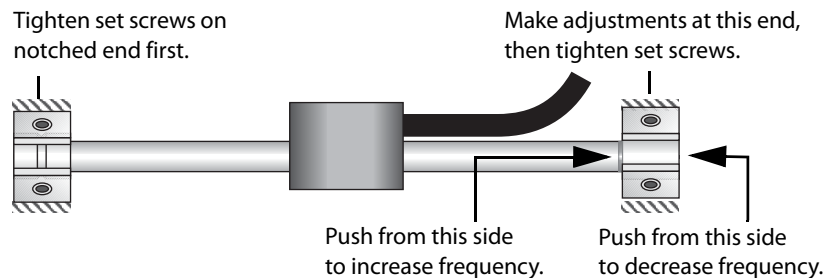

1. Slide the strain gauge into the mounting blocks.
2. Tighten set screws at the notched-end of the gauge. Do not tighten set screws at the adjustment-end of the gauge.
3. Connect the readout. Choose the “Hz” and observe the reading. A reading of 780 Hz is approximately mid-range and is satisfactory for most applications.
4. To adjust the starting frequency, push gently on the adjustment-end of the gauge in the directions shown in the drawing. To maximize the range for tensile strains, set a lower starting frequency (about 500 Hz). To maximize the range for compressive strains, set a higher starting frequency (about 990 Hz).
5. Tighten the set screws. The readings may change, but it is not necessary to be precise.

Taking Readings

Introduction

These instructions tell how to read the strain gauge with Slope Indicator's portable readouts.

Instructions for reading VW sensors with a Campbell Scientific CR10 can be found at www.slopeindicator.com. Go to Support - Tech Notes and click on the link titled "CR10-VW Sensors."

Reading with the VW Data Recorder

1. Connect signal cable to the data recorder:

Binding Posts	Wire Colors	
VW	Orange	Red
VW	White & Orange	Black
TEMP	Blue	White
TEMP	White & Blue	Green
SHIELD	Shield	Shield

2. Choose Hz + RTD or Hz + Thermistor.
3. Select the 450-1200 Hz range.
4. The recorder displays a sensor reading in Hz and a temperature reading in degrees C.

Reading with the VWP Indicator

1. Connect signal cable to the VWP indicator as shown in the tables below.
2. Select the 0.45-1.2 kHz range with the Sweep key.
3. Select Hz with the Data key. Do not use microstrain settings (these are for a different model of sensor).
4. Read the RTD: Select °C with the Data key.
Note that the VWP Indicator reads RTDs only and cannot read thermistors.

Standard Jumper 52611950

Connect alligator clips as shown below:

Clips	Wire Colors		Function
Red	Orange	Red	VW
Red	White & Orange	Black	VW
Black	Blue	White	TEMP
Black	White & Blue	Green	TEMP

Universal Jumper 52611957



This cable has a universal connector and is supplied with a bare-wire adapter:

BWA	Wire Colors		Function
5	Blue	White	TEMP
6	White & Orange	Black	VW
7	White & Blue	Green	TEMP
8	Orange	Red	VW
10	Shield	Shield	Shield

Reading with the DataMate MP

The DataMate MP allows you to choose engineering units for your readings. However, for ease of data reduction, we recommend that you record readings in Hz.

Manual Mode

1. Connect signal cable as shown in the table below.
2. Switch on. Press  (Manual Mode).
3. Scroll through the list to find “Vibrating Wire Hz.”
4. Press  to excite the sensor and display a reading in Hz and a temperature reading in degrees C.

Universal Jumper and Bare-Wire Adapter

The DataMate jumper cable has a universal connector that connects directly to a universal terminal box or to signal cables that are terminated with a universal connector. A bare-wire adapter (BWA) is also supplied with the DataMate. It allows connection to wires of the signal cable as shown below:

Terminals on BWA or Terminal Box	Wire Colors		Function
	Blue	White	
5	Blue	White	TEMP
6	White & Orange	Black	VW
7	White & Blue	Green	TEMP
8	Orange	Red	VW
10	Shield	Shield	Shield

Data Reduction

Converting from Hz to microstrain

Use the following equation to convert a reading in Hz to microstrain:

$$\mu\varepsilon = F^2 \times \text{Gauge-Factor} \times \text{Batch-Factor}$$

Where:

$\mu\varepsilon$ = microstrain

F is a reading in Hz.

Gauge-Factor = 4.062×10^{-3}

Batch-Factor = 0.96

Calculating $\Delta\mu\varepsilon$

Change in strain is calculated by subtracting the initial strain from the current strain:

$$\Delta\mu\varepsilon = \mu\varepsilon_{\text{current}} - \mu\varepsilon_{\text{initial}}$$

or

$$\Delta\mu\varepsilon = (F_{\text{current}}^2 - F_{\text{initial}}^2) \times \text{Gauge-Factor} \times \text{Batch-Factor}$$

Where:

$\mu\varepsilon$ = microstrain

$\Delta\mu\varepsilon$ = change in microstrain

F is a reading in Hz.

Gauge-Factor = 4.062×10^{-3}

Batch-Factor = 0.96

Tension or Compression?

Using the equation above:

- a positive $\Delta\mu\varepsilon$ indicates tensile strain.
- a negative $\Delta\mu\varepsilon$ indicates compressive strain.

Temperature Effects

- We recommend that you always record temperature when you record strain readings. You can then use the temperature data as well as strain data to characterize the behavior of the structure.
- The steel used for the wire in the strain gauge has a thermal coefficient of expansion similar to that of steel used in structures. Thus, if the gauge and the steel are at the same temperature, no correction for temperature corrections are required.
- If the gauge is heated by direct sunlight, so that its temperature increases faster than that of the structural steel, you may see large changes in apparent strain. It is difficult to correct for this, so try to shield gauges from direct sunlight.
- If the steel in the structure has a different thermal coefficient that is quite different from structural steel, a temperature correction might be appropriate.

$$\Delta\mu\varepsilon \text{ corrected} = \Delta\mu\varepsilon - (TC_m - TC_g) \times (\text{Temp}_1 - \text{Temp}_0)$$

Where

$\Delta\mu\varepsilon$ is the change in strain,

TC_m is the thermal coefficient of the member

TC_g is the TC of the gauge: $12.2 \mu\varepsilon/^\circ\text{C}$

Temp_1 is the current temperature

Temp_0 is the datum temperature