

# EL Beam Sensors

Standard & SC Versions

56801399

Copyright ©2008 Slope Indicator Company. All Rights Reserved.

This equipment should be installed, maintained, and operated by technically qualified personnel. Any errors or omissions in data, or the interpretation of data, are not the responsibility of Slope Indicator Company. The information herein is subject to change without notification.

This document contains information that is proprietary to Slope Indicator company and is subject to return upon request. It is transmitted for the sole purpose of aiding the transaction of business between Slope Indicator Company and the recipient. All information, data, designs, and drawings contained herein are proprietary to and the property of Slope Indicator Company, and may not be reproduced or copied in any form, by photocopy or any other means, including disclosure to outside parties, directly or indirectly, without permission in writing from Slope Indicator Company.

## **SLOPE INDICATOR**

12123 Harbour Reach Drive  
Mukilteo, Washington, USA, 98275  
Tel: 425-493-6200 Fax: 425-493-6250  
E-mail: [solutions@slope.com](mailto:solutions@slope.com)  
Website: [www.slopeindicator.com](http://www.slopeindicator.com)

---

# Content

Introduction .....	1
Installing Horizontal Beam Sensors .	3
Installing Vertical Beam Sensors ....	7
Zero Adjusting Standard Sensors ..	11
Reading Standard Sensors.....	14
Zero Adjusting SC Sensors.....	15
Reading SC Sensors .....	19
Data Reduction .....	21

# Introduction

## Operating Principle

EL beam sensors monitor rotation and differential movement in structures. Horizontal beams sensors are used to monitor settlement and heave. Vertical beams monitor lateral displacements. Linked end to end, beam sensors can monitor differential movements.

The beam sensor consists of an electrolytic tilt sensor attached to a rigid metal beam. The tilt sensor is a precision bubble-level that is sensed electrically as a resistance bridge. The bridge circuit outputs a voltage proportional to the tilt of the sensor.

The beam, which is typically one to two meters long, is mounted on anchor bolts that are set into the structure. Movement of the structure changes the tilt of the beam and the output of the tilt sensor.

The voltage reading from the tilt sensor is converted to a reading in mm per meter. Displacement is calculated by subtracting the initial reading from the current reading.

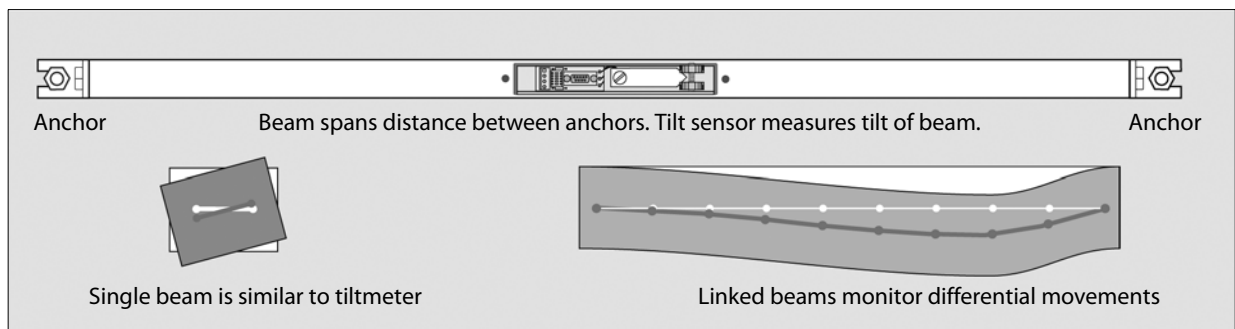

## Beam Sensor Components

Beam sensor components include a beam with end brackets, an anchor kit, an EL tilt sensor, and a terminal board.

### Beams

Beams are square section aluminum beams supplied in gauge lengths up to 2 meters. End brackets are included with each beam. The horizontal beam has a built-in compartment and cover for the tilt sensor. The vertical beam has no compartment, since the sensor is supplied with a separate housing that clamps onto the beam.

Each beam is supplied with end-brackets that can be secured directly to wall anchors. This method of installation is satisfactory with solitary beams that only rotate. However, if beams are linked, or if the structure is likely deform, the mounting hardware included in the anchor kit will provide better results.

### Anchor Kit

The anchor kit contains one stainless steel M10 x 200 mm all-thread stud, an angle bracket, low-friction bushings, and other hardware. Use two anchor kits for a single beam. Linked beams share anchors, so use one anchor kit for each beam plus one anchor kit for the last beam.

### EL Tilt Sensor

The horizontal tilt sensor fits inside the horizontal beam. The vertical beam is supplied in a separate housing that clamps onto the beam.

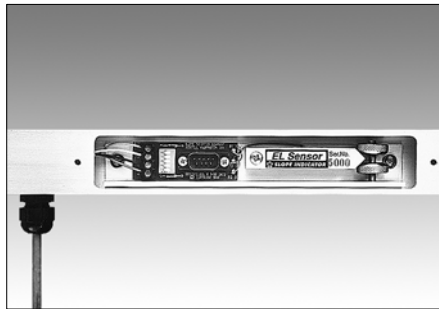

Horizontal tilt sensor

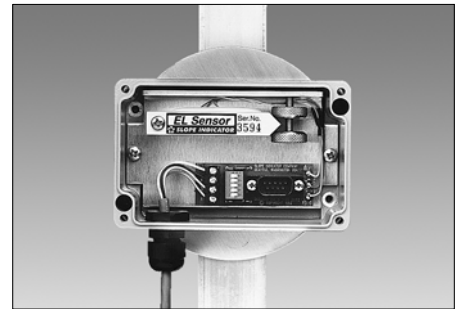

Vertical tilt sensor

### Terminal Board

The tilt sensors may be supplied with a standard terminal board or an SC (Signal Conditioning) terminal board. Wiring and reading methods differ according to the type of board supplied.

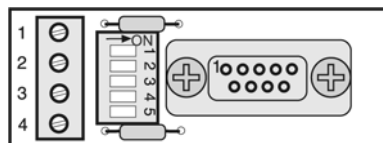

Standard terminal board has 4 terminals. Other notable features are a DB9 connector and a bank of switches.

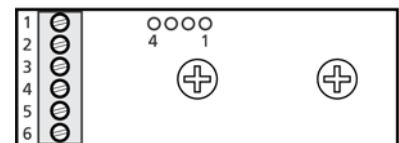

SC terminal board has 6 terminals. The only other notable feature is the row of four pins at the top of the board.

---

# Installing Horizontal Beam Sensors

## Installation Overview

1. Install anchors.
2. Mount sensor inside beam.
3. Install beam.

## Installation Materials

- Quick-set epoxy grout, 250 ml or larger package. This is used to secure the all thread anchors in the drill holes.
- Blue Loctite (#242) or equivalent thread-locking compound to keep the sensor in its adjusted position.
- Teflon tape (optional). To be wrapped on anchors to prevent bonding of grout and anchor. Used when anchors must be removed.

## Installation Tools

- Spirit level.
- Percussion/hammer drill with 12 to 19 mm masonry drill bit.
- Two adjustable wrenches.
- Two screw drivers, one flat head and one phillips.

---

## Installing Anchors

The beam sensor monitors the relative movement of two anchors. The gauge length of the beam sensor is the distance between the center point of each anchor. You can choose any convenient gauge length. For example, you can have some anchors spaced at 1.5 meters and other anchors at 0.8 meters.

Once anchors are grouted in, you must measure the center to center distance between each anchor carefully, since this value is used in displacement calculations.

1. Mark locations for anchor holes: Draw a horizontal line on the structure, then mark off gauge lengths for each sensor. Linked beams share anchors.
2. Drill anchor holes to depth of about 100 mm. Take care to drill holes at same angle.
3. Remove debris from holes. Mix epoxy grout as directed by manufacturer. Fill hole with grout, then insert anchor.
4. Allow grout to harden before mounting beam.
5. Measure the center to center distance between each pair of anchors.

## Mounting Sensor Inside Beam

Skip these instructions if the EL sensor is already mounted inside the beam.

1. Remove cover plate from sensor compartment. Sensor compartment is located in middle of beam.
2. Remove the two mounting screws from back of sensor assembly.
3. Place sensor assembly in sensor compartment, so that mounting holes are aligned with pre-drilled holes in beam.
4. Insert mounting screws through back of beam and into sensor assembly. Tighten screws until sensor assembly is securely fastened to beam.
5. Replace cover plate.

## Installing the Beam

Each beam is supplied with end-brackets that can be secured directly to wall anchors. This method of installation is satisfactory with solitary beams that monitor only rotation. However, if beams are linked, or if the structure is likely to deform, the mounting hardware included in the anchor kit will provide better results. See installation drawings below and on the next page.

1. Check that anchors are parallel. Adjust anchors by bending the line, if necessary.
2. Check that end brackets are inserted into beams, but not completely tight.

3. Fasten angle brackets to anchors, as shown in the drawing at right.

4. Fasten end bracket of beam sensor to angle brackets. Hardware is usually supplied with all washers in place. Use drawing below to see where end brackets and angle brackets fit. Tighten nuts so that spring washers are just slightly compressed.

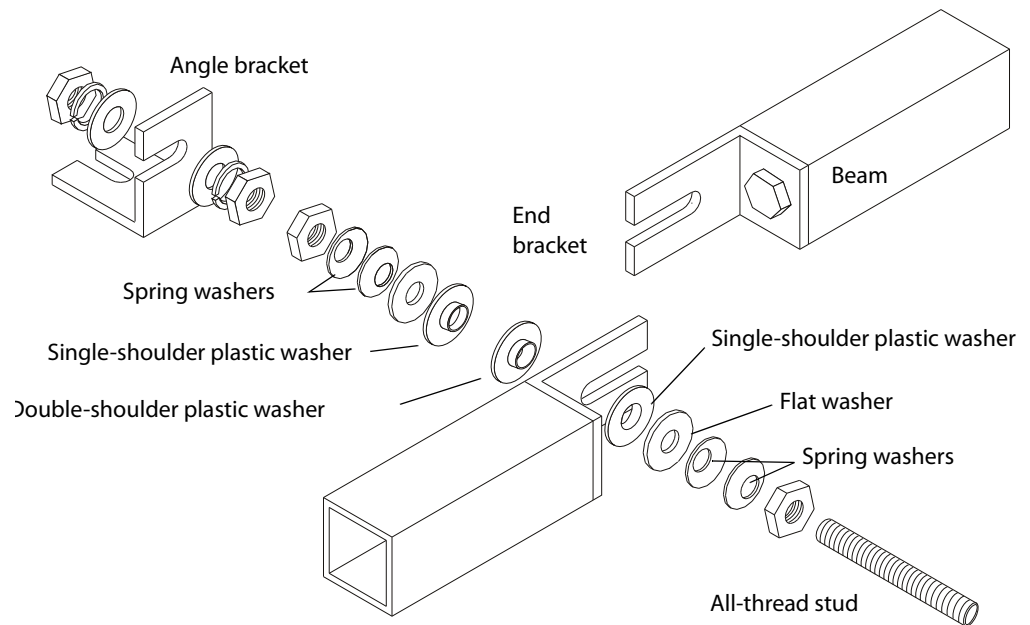
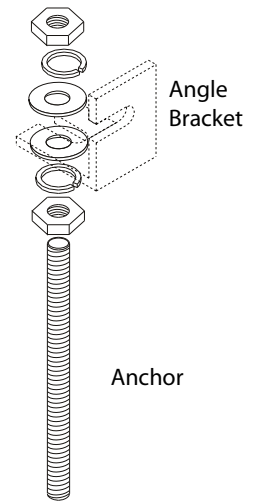

Installing the Beam  
continued

5. Check that beam is properly oriented, as shown in the drawings below. Apply thread-locking compound to all nuts.

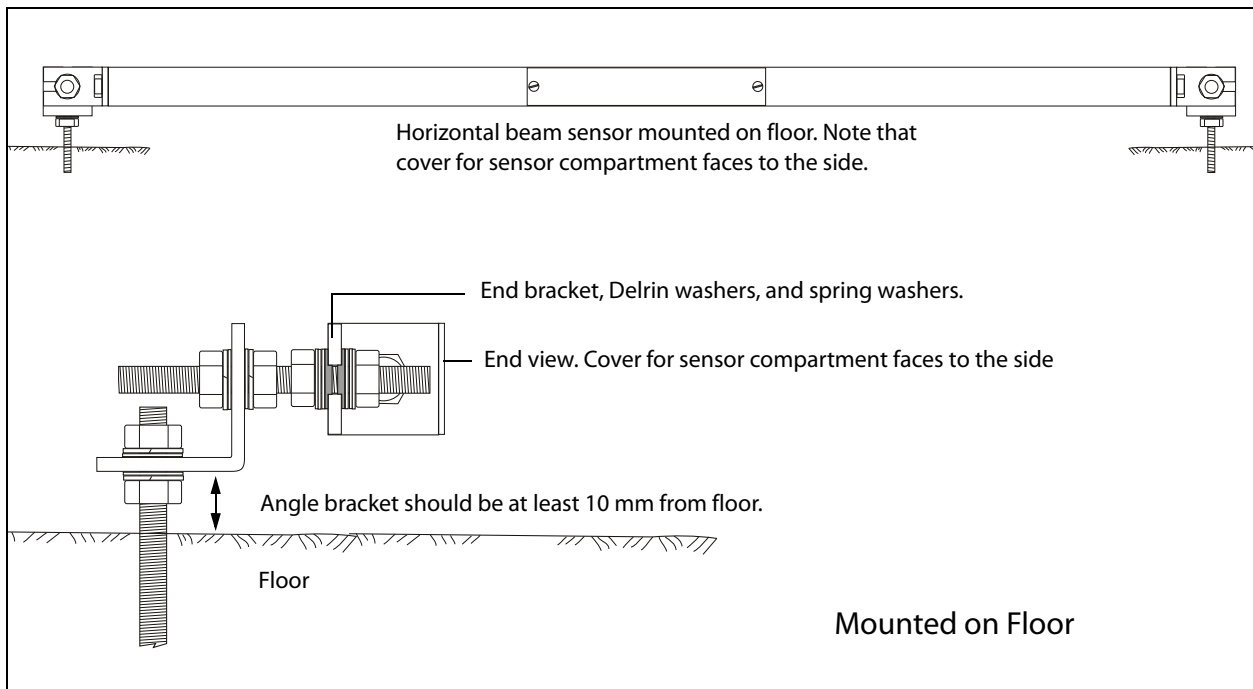
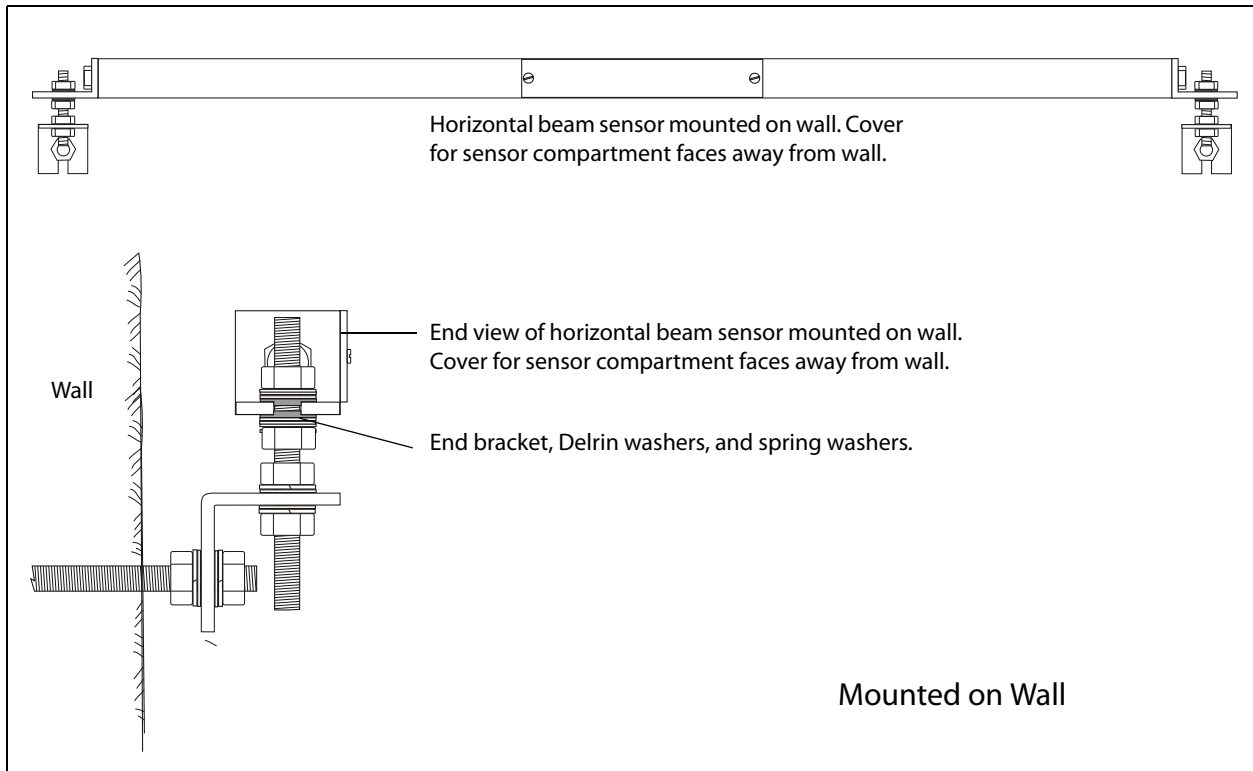



---

# Installing Vertical Beam Sensors

## Installation Overview

1. Install anchors.
2. Attach sensor housing to beam.
3. Install beam.

## Installation Materials

- Quick-set epoxy grout, 250 ml or larger package. This is used to secure the all thread anchors in the drill holes.
- Blue Loctite (#242) or equivalent thread-locking compound to keep the sensor in its adjusted position.
- Teflon tape (optional). To be wrapped on anchors to prevent bonding of grout and anchor. Used when anchors must be removed.

## Installation Tools

- Spirit level.
- Percussion/hammer drill with 12 to 19 mm masonry drill bit.
- Two adjustable wrenches.
- Two screw drivers, one flat head and one phillips.
- 8 mm socket wrench, used to tighten nuts on swivel plate.

## Installing Anchors

The beam sensor monitors the relative movement of two anchors. The gauge length of the beam sensor is the distance between the center point of each anchor. You can choose any convenient gauge length. For example, you can have some anchors spaced at 1.5 meters and other anchors at 0.8 meters.

Once anchors are grouted in, you must measure the center to center distance between each anchor carefully, since this value is used in displacement calculations.

1. Mark locations for anchor holes: Draw a vertical line on the structure, then mark off gauge lengths for each sensor. Linked beams share anchors.
2. Drill anchor holes. Take care to drill holes at same angle. Do not use end-brackets as drill guides, since enlargement of slot may interfere with performance of beam sensor.
3. Remove debris from holes. Mix epoxy grout as directed by manufacturer. Fill holes with grout, then insert anchors. Anchor must extend at least 100 mm from wall to provide clearance for sensor housing.
4. Allow grout to harden before mounting beam.
5. Measure the center-to-center distance between each pair of anchors.

## Attaching the Sensor to the Beam

1. Remove cover.
2. Attach mounting plate and disks to sensor housing, as shown below. With beam held vertical.
3. Replace cover.
4. Clamp sensor housing to beam. Tighten nuts on clamp.

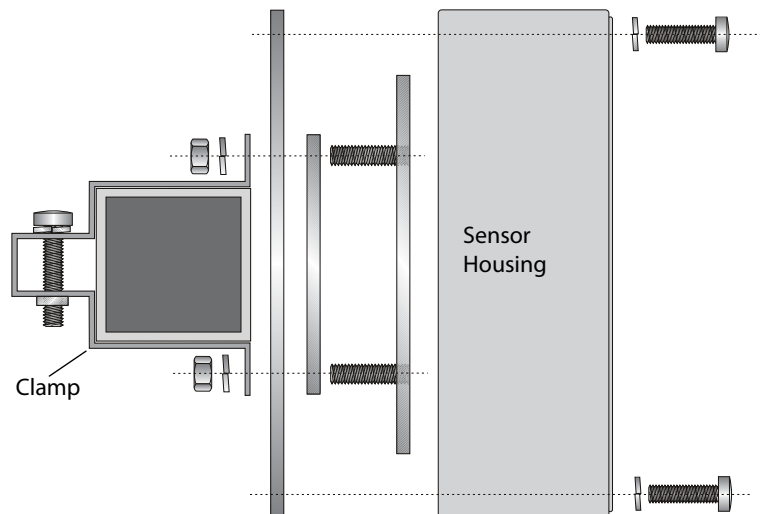

## Installing the Beam

Each beam is supplied with end-brackets that can be secured directly to wall anchors. This method of installation is satisfactory with solitary beams that monitor only rotation. However, if beams are linked, or if the structure is likely to deform, the mounting hardware included in the anchor kit will provide better results.

See installation drawings below and on the next page.

1. Check that anchors are parallel. Adjust anchors by bending, if necessary.
2. Fasten angle-brackets onto anchor.
3. Fasten end-brackets of beam to angle brackets. Check that washers are inserted as in the drawing on page 5. Tighten nut so that spring washers are just slightly compressed.

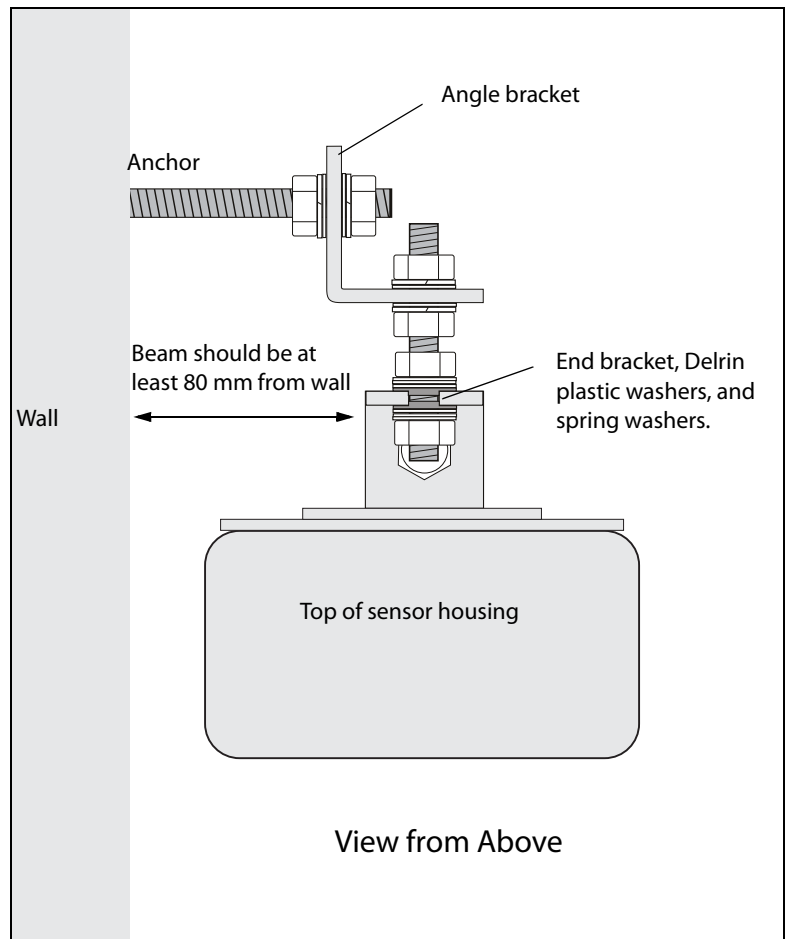

4. Viewed from the front, beam should be near vertical. Viewed from the side, the beam should be roughly parallel with the wall.
5. Check that top of sensor housing is level. To adjust, remove cover, loosen the two mounting screws, and rotate housing. Then tighten mounting screws and replace cover.
6. Apply thread-locking compound to all nuts.

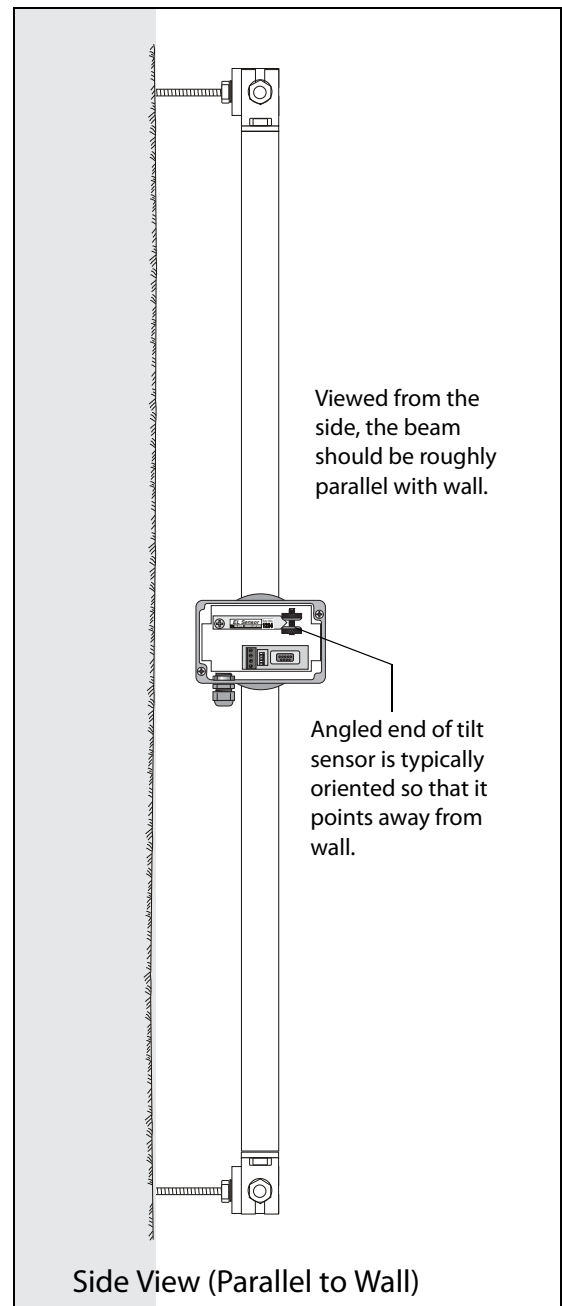
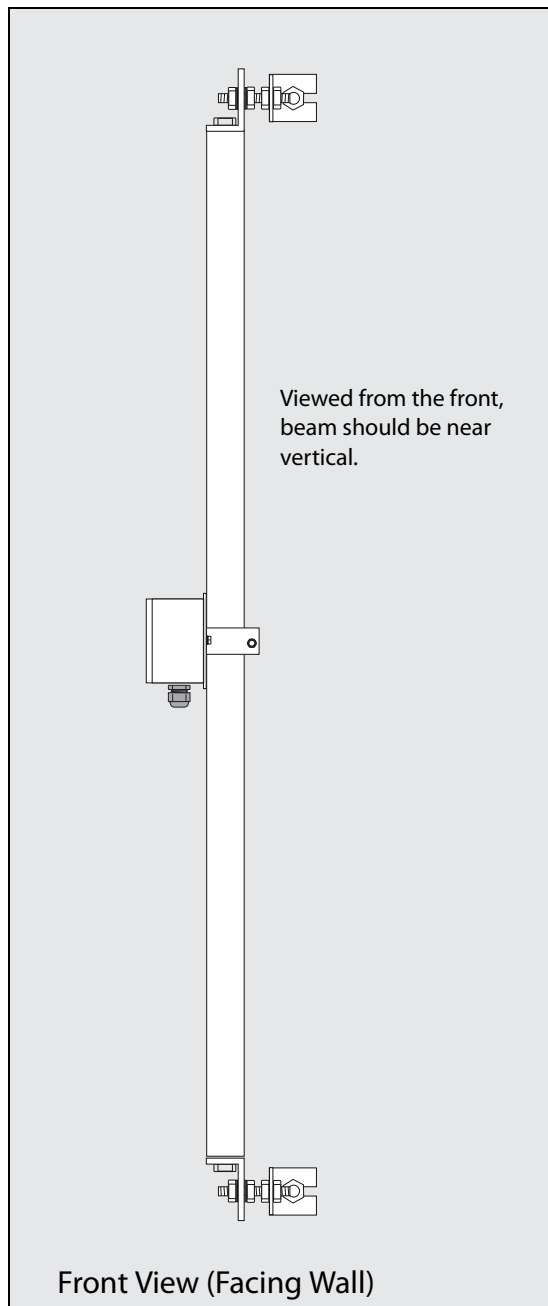

# Zero-Adjusting Standard Sensors

## Introduction

The EL tilt sensor has a very narrow range, so it must be adjusted so that its initial output is as close as possible to null. This makes the full tilt range of the sensor available for monitoring.

The standard terminal board has a DB9 socket for connecting a zeroing device.

Horizontal tilt sensor with standard terminal board.

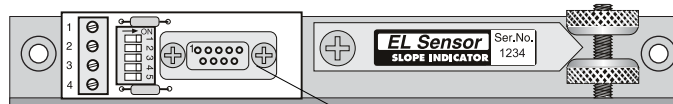

Vertical tilt sensor with standard terminal board.

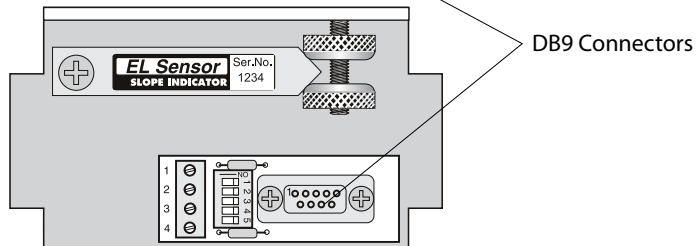

## Overview of Zeroing

1. Connect signal cable to the sensor. The sensor is very sensitive to even small movements, so it is best to connect signal cable to it before you attempt to zero the sensor. Otherwise, you may have to re-zero the sensor when you connect the cable.
2. Zero the sensor using the EL Zeroing Device, the DataMate MP readout, or the EL-35 (a retired zeroing device).

## Connect Signal Cable

1. Remove cover of sensor housing.
2. Set switches 1 through 4 to the OFF position.

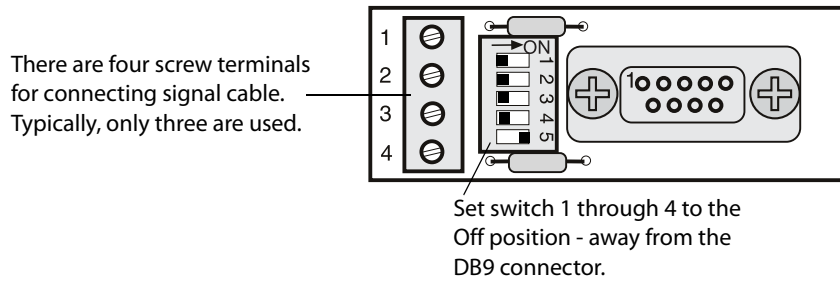

3. Connect signal cable as shown in the table below:

Standard Terminal	Cable 50612804	Function
1	White	AC Excitation
2	not used	
3	Green	AC Output
4	Red	Analog Ground
	Drain	Not connected to sensor

4. Secure the signal cable to the wall or floor so that it will not cause the sensor to move. Note that any testing of the signal cable should be performed with switches 1 through 4 in the “Off” position. This prevents cable-test operations from damaging the sensor.

## Zero the Sensor

1. Set switches on terminal board. Switches 1 through 4 should be OFF. Switch 5 should be ON.

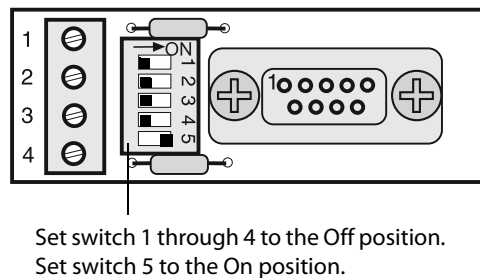

2. Connect the EL zeroing device or DataMate MP to the DB9 socket on sensor board and switch on.

If you are using a DataMate MP, use adapter #57710958 to connect to the DB9 socket. Then choose EL 35 RO from the manual mode sensor list. If you do not have the DB9 adapter, you can connect using the bare wire adapter, but you must set the switches differently. See note below.

3. Adjust sensor to zero tilt: Loosen sensor mounting screw and the two thumb nuts to allow adjustment of tilt sensor. Use the thumb nuts to adjust the sensor up or down. With the zeroing device, the object is to light the middle LED. With a DataMate MP, the object is to get the reading as close to zero as possible.

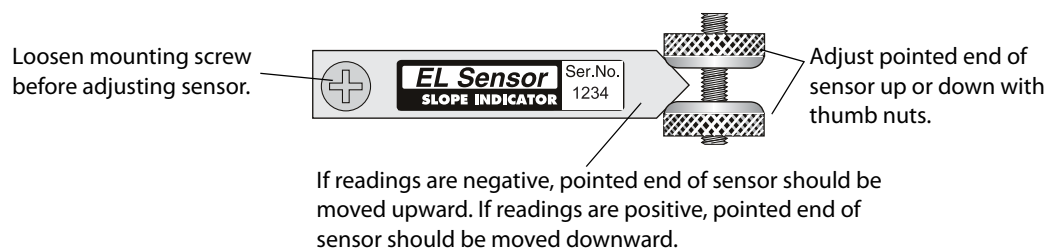

4. Turn thumb nuts until both are in contact with the sensor, then gently tighten the mounting screw. Finger tight is good enough. Over-tightening can cause the reading to change and stress the sensor.
5. Check that the sensor is still zeroed, then switch off and gently disconnect the zeroing device. Make a note of sensor location and serial number.
6. Apply thread-locking compound to prevent screw and nuts from turning. Note that you may need to adjust sensor again later, so do not use a permanent compound.
7. Finally, carefully reset the switches for CR10 operation: switches 1, 3, and 4 are ON and switches 2 and 5 are OFF.

Note: Using the DataMate MP Bare-Wire Adapter for Zeroing

1. Set all switches to the ON position.
2. Connect the bare wire adapter as follows:

Bare Wire Adapter	Tilt Sensor Terminal
5	1
2	2
1	3
6	4

# Reading Standard Sensors

**Data Logging** The standard sensor must be read with a CR10X data logger. These instructions below assume that signal cable is already connected to the sensor, as explained in the previous chapter.

**CR10X Instructions** Use the P78 and P5 instructions for single ended channels.

**P78 (Resolution)** • High Resolution

**P5 (AC Half Bridge)** • 2500 mV Fast Range  
• 2500 mV Excitation  
• Multiplier (10)

**Wiring for CR10X** The exact wiring for the CR10X depends on your program and whether you use multiplexers or not. A generic connection is shown in the table below. You can download a sample monitoring program from [www.slopeindicator.com](http://www.slopeindicator.com). Go to Support - Technotes- Data Loggers. Then find a link for sample programs.

CR10 Terminals	Wire Color 50612804	Sensor Terminal	Function
E	White	1	AC Excitation
		2	Not Used
H or L	Green	3	AC output
AG	Red	4	Analog Ground
G	Drain	Drain wire not connected to sensor	

**Setting Switches for CR10X** 3. Set the switches as shown below.

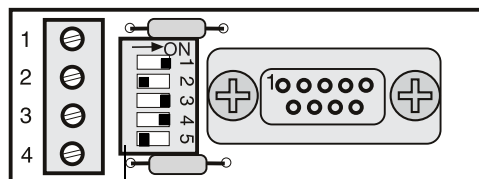

Switches 1, 3, and 4 are ON.  
Switches 2 and 5 are OFF



# Zero Adjusting SC Sensors

## Introduction

Because the EL tilt sensor has a very narrow range, it must be adjusted so that its initial output is as close as possible to null. This makes the full range of the sensor available.

Sensors equipped with the SC terminal board, illustrated below, can be zeroed with the EL Data Recorder, the DataMate MP, or a voltmeter.

Horizontal tilt sensor with SC terminal board.

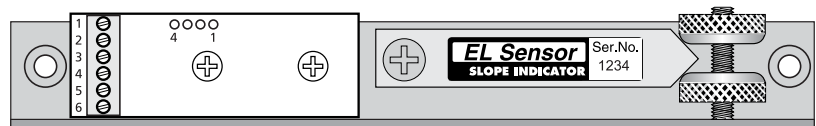

Vertical tilt sensor with SC terminal board.

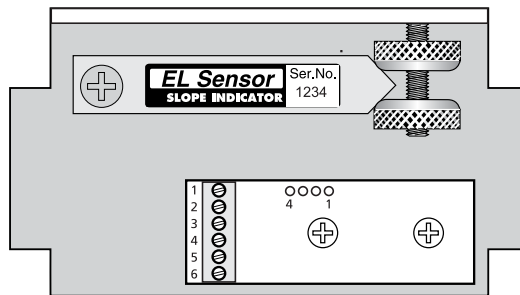

## Overview of Zeroing

1. Connecting signal cable to the sensor. The sensor is very sensitive to even small movements, so it is best to connect signal cable to it before you attempt to zero the sensor. Otherwise, you may have to zero the sensor again after the signal cable is connected.
2. Zero the sensor using the EL Data Recorder, the DataMate MP, or a voltmeter.

## Connect Signal Cable

The drawing shows the SC terminal board. Connect signal cables as shown in the table below. After connecting the signal cable, secure it to the wall or floor so that it will not cause the sensor to move

There are six screw terminals for connecting signal cable.

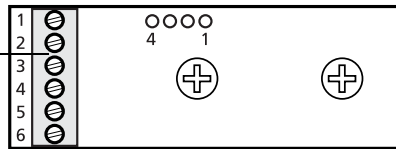

SC Terminal Board	Cable 50613527	Function
1	Green	+ Power
2	Black	- Power
3	Orange	Tilt
4	Yellow	Signal Common
5	Red	Temperature
6	Violet	Sense

## Connect a Readout

Connect the EL Data Recorder, the DataMate MP or a Voltmeter to the sensor.

### EL Data Recorder

1. Connect sensor to readout as shown in the table below.
2. Switch on. Choose uniaxial sensor. Tilt is displayed in volts. Temperature is displayed in degrees C.

Data Recorder Terminal	Signal Cable Wire	SC Terminal Board
1 Tilt A	Orange	3
2		
3 Temp	Red	5
4 Sig Common	Yellow	4
5 Sense	Violet	6
6 Power +	Green	1
7 Power -	Black	2
8 Shield	Drain Wire	

---

DataMate MP      DataMate MP must have firmware version 05/01/02 AA or later.

1. Connect sensor as shown in table below
2. Switch on. Choose Manual mode. Choose EL SC RO. “A-axis” tilt is displayed in volts. Ignore “B-axis” value. Temperature is displayed in degrees C..

Bare Wire Adapter	7-Wire Cable	SC Board	Function
1	Orange	3	Tilt
2	Yellow	4	Signal Common
5	Red	5	Temperature
6	Black	2	Power -
	Violet	6	Sense
7	(Yellow)	4	Signal Common
8	Green	1	Power +
Use a jumper wire to connect terminals 2 and 7 of the bare-wire adapter. Black and violet wires are both connected to terminal 6.			

**Voltmeter**      In addition to a voltmeter, you must have a power source, such as a 9-volt battery to supply between 7.5 and 14 Vdc to the sensor.

1. Connect the green wire to the + terminal of the battery.
2. Connect the violet wire and black wire to the - terminal of the power source.
3. To read the tilt, connect the voltmeter to the orange wire and the yellow wire.
4. To read the thermistor, connect the voltmeter to the red wire and the yellow wire.

## Adjusting Zero

1. Adjust sensor to zero tilt: Loosen sensor mounting screw and thumbscrews to allow adjustment of tilt sensor. Use thumb nuts to adjust sensor up or down according to the sign (+ or -) of the reading. The object is to get the reading as close to zero as possible.

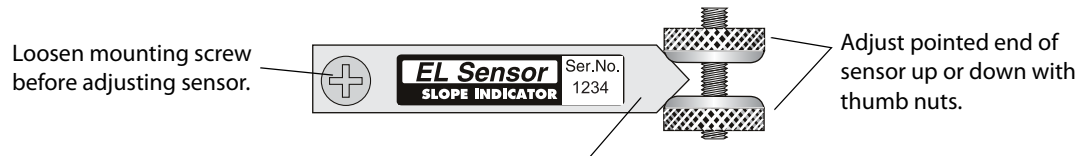

If readings are negative, pointed end of sensor should be moved upward.

If readings are positive, pointed end of sensor should be moved downward.

2. Turn thumb nuts until both are in contact with the sensor, then gently tighten the mounting screw. Finger tight is good enough. Over-tightening can cause the reading to change and stress the sensor.
3. Check that reading is still zeroed, then disconnect the read-out. Make a note of sensor location and serial number and replace the cover.
4. Apply thread-locking compound to prevent screw and nuts from turning. Note that you may need to adjust sensor again later, so do not use a permanent compound.

---

# Reading SC Sensors

**Introduction** Beam sensors are generally connected to data loggers. However, with the SC version of the beam sensor, you can also obtain readings with an EL Data Recorder, a DataMate MP, or a precision voltmeter (one capable of reading to hundredths of a millivolt).

**Manual Readings**

1. Connect the readout to the sensor signal cable as described in the previous chapter.
2. Obtain the reading and write it down or record it.
3. Later, apply calibration factors to convert the reading in volts to engineering units, as described in the chapter on Data Reduction.

Additional information about the EL Data Recorder or DataMate MP can be found on Slope Indicator's website. Go to [www.slopeindicator.com](http://www.slopeindicator.com). Click on Support, then click on Technotes. Find the Readout section and click on the link for EL Data Recorder or DataMate MP.

## Data Logging

These wiring diagrams show how to connect SC sensors to a Campbell Scientific CR10X data logger. You can download a sample monitoring program from Slope Indicator's website. Go to [www.slopeindicator.com](http://www.slopeindicator.com) - support - tech notes. Look at the data logger technotes to find a link for sample programs that you can download.

Wiring Diagram 1 Connecting a uniaxial sensor directly to the CR10X

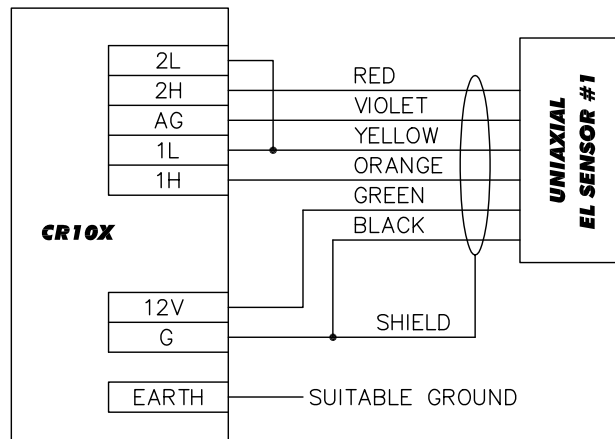

Wiring Diagram 2 Connecting a uniaxial sensor to an AM416 multiplexer

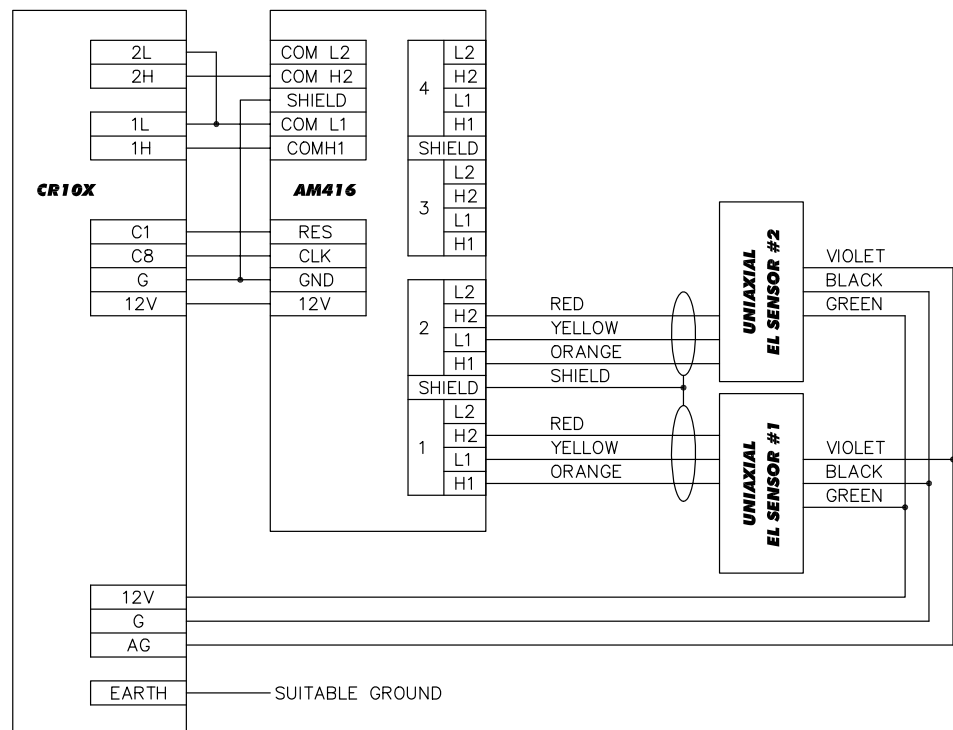

---

# Data Reduction

**Overview** Data reduction is usually automated because it involves a large number of readings and a large number of calculations. Here, we explain the manual operations required to convert voltage readings to mm of displacement.

1. The EL tilt sensor produces a voltage value that is recorded by the readout or data logger. To convert the voltage value to a tilt value, you must apply calibration factors listed on the sensor calibration sheet.
2. The factors on the sensor calibration sheet are coefficients for a 5th order polynomial equation. Processing the voltage reading with this equation transforms the voltage reading into tilt in units of mm per meter. (Think of this tilt value as “grade” in tenths of a percent).
3. Multiply the tilt by the gauge length of the beam sensor (the center-to-center distance between anchors). This results in a reading in mm.
4. To find displacement, the distance that one anchor has moved relative to the other, subtract the initial reading in mm from the current reading in mm.

## Data Reduction Example

Suppose you obtain a reading of -0.58571 volts from the sensor.

### Calibration Sheets

Find the calibration sheet for your sensor. In this case, we show factors for sensor 8889. The factors on your calibration sheets will be different.

These factors are coefficients for a 5th order polynomial expression.

C5	1.6426E-1
C4	-1.5836E-2
C3	-2.6881E-1
C2	-7.9904E-2
C1	3.5098
C0	8.1185E-2

### Convert voltage reading to tilt in mm per meter

Process the voltage reading with the polynomial equation shown below. C5 through C0 are the coefficients that appear on the sensor calibration record. EL is the voltage reading from the sensor, in this case 0.144 V. The result of the calculation is a value in mm per meter.

$$\text{mm/meter} = C5 \cdot EL^5 + C4 \cdot EL^4 + C3 \cdot EL^3 + C2 \cdot EL^2 + C1 \cdot EL + C0$$

	C Factor	EL Reading	Value
C5	1.6426E-1	-0.58571 <sup>5</sup>	-0113225700
C4	-1.5836E-2	-0.58571 <sup>4</sup>	-0.0018637002
C3	-2.6881E-1	-0.58571 <sup>3</sup>	0.0540123829
C2	-7.9904E-2	-0.58571 <sup>2</sup>	-0.0274115629
C1	3.5098	-0.58571 <sup>1</sup>	-2.0557249580
C0	8.1185E-2	1	0.0811850000
mm per meter deviation =			-1.9611254082

### Apply gauge length

Multiply the mm/meter value by the gauge length of the sensor.

$$\text{reading in mm} = \text{mm/meter value} \cdot \text{gauge length of sensor}$$

In this example, the gauge length of the beam is 2 meters, so the reading in mm is 2 x -1.961 or about -3.922 mm.

### Calculate Displacement

To calculate displacement, subtract the initial reading from the current reading.

$$\text{displacement in mm} = \text{current reading} - \text{initial reading.}$$

If the initial reading were 0.5 mm, then displacement would be about -3.4 mm. See Direction of Movement on the next page for help in understanding this reading.



## Direction of Movement

The beam sensor spans the distance between two anchors. When the beam sensor reading changes, it means that one anchor has moved relative to the other anchor.

- With horizontal sensors, one anchor has moved up or down relative to the other anchor.
- With vertical sensors, one anchor has moved laterally (right or left) relative to the other anchor.

## Tilt of the Sensor

In the process of zeroing the sensor, you move its angled end up or down relative to the mounting screw. Moving the angled end above horizontal results in a positive (+) reading. Moving the angled end below horizontal results in a negative (-) reading.

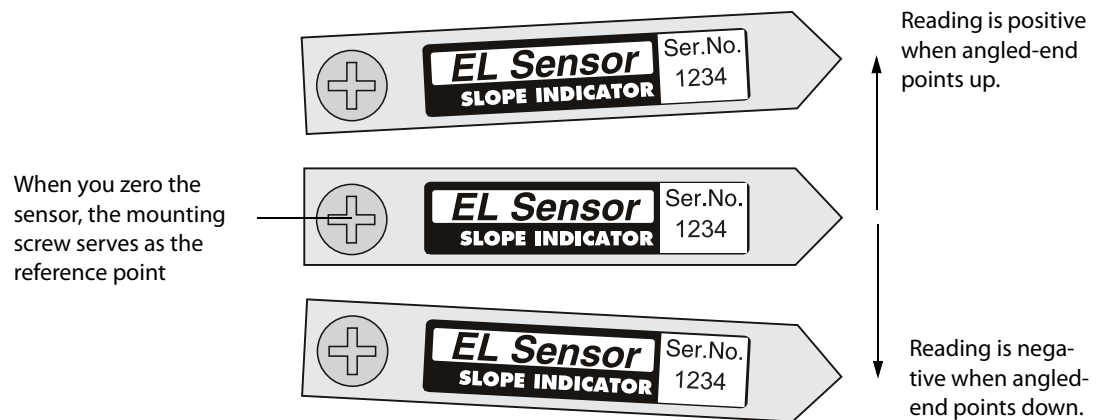

Note that the relation of up-positive and down-negative would be reversed if you held the angled-end of the sensor and moved the screw end up or down.

Thus in determining the direction of movement, you must choose a reference point. In the case of the beam sensor, you must choose an anchor to serve as the reference, as shown on the next page.

## Reference Point and Direction of Movement

The drawings below show how the reference point affects the direction of movement.

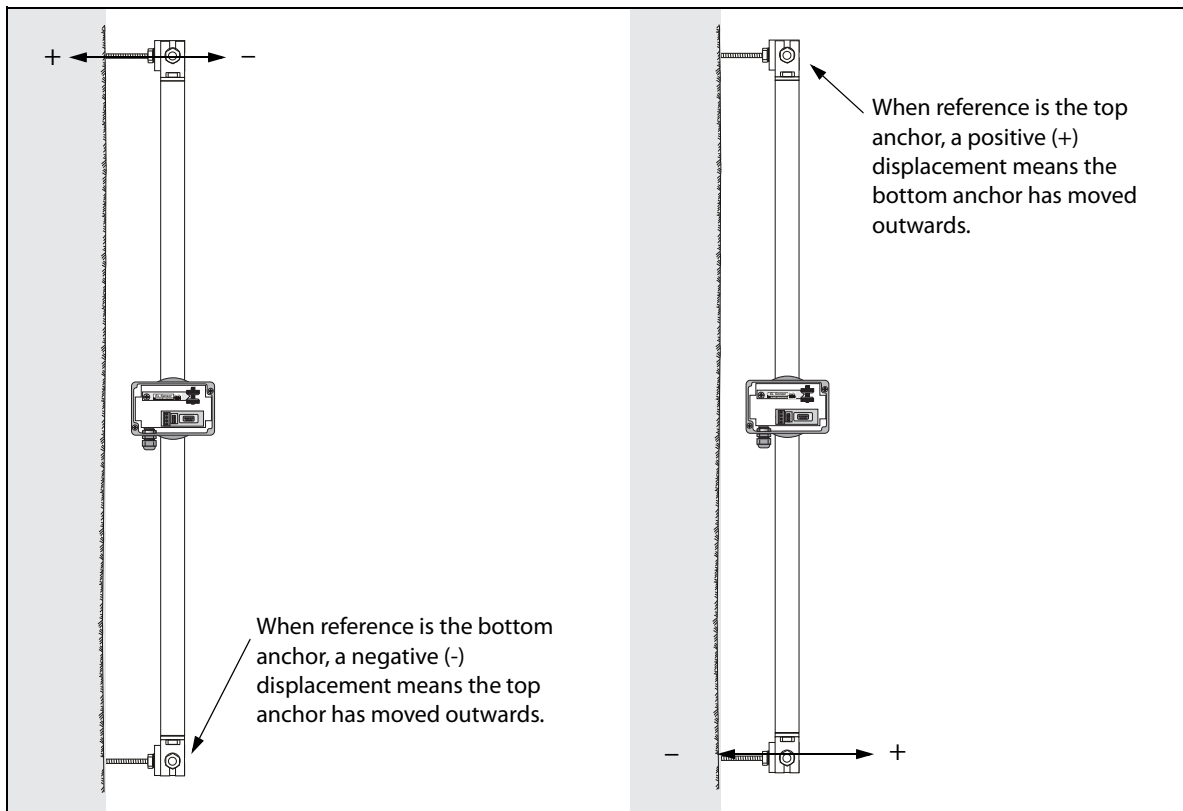
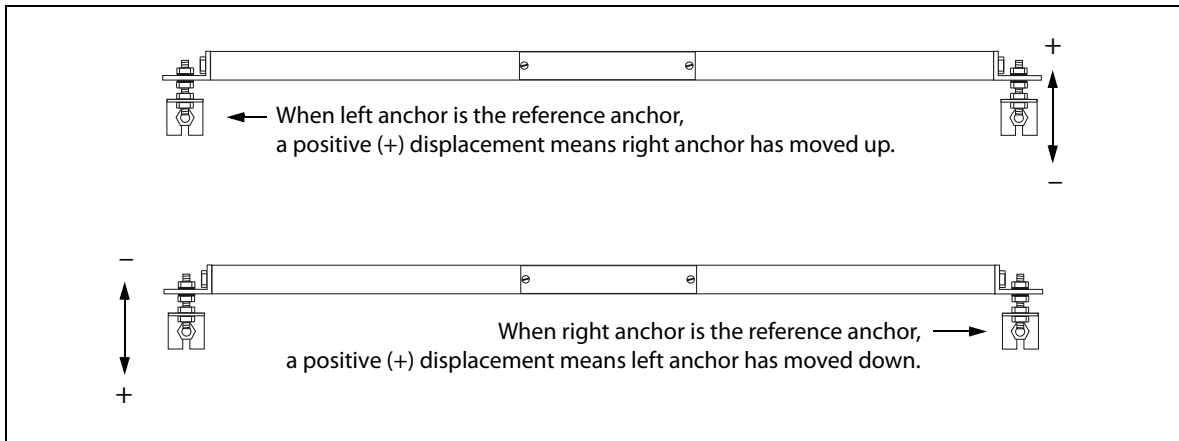

## Converting the thermistor reading to degrees C.

SC terminal boards are equipped with a thermistor. If you have obtained a thermistor reading in volts, use the equation below to convert volts to degrees C. ET is the thermistor reading in volts.

$$\text{DegC} = 58.6752 \cdot \text{ET}^5 - 278.839 \cdot \text{ET}^4 + 509.188 \cdot \text{ET}^3 - 449.099 \cdot \text{ET}^2 + 233.754 \cdot \text{ET} - 48.4917$$