

## Pneumatic Piezometer

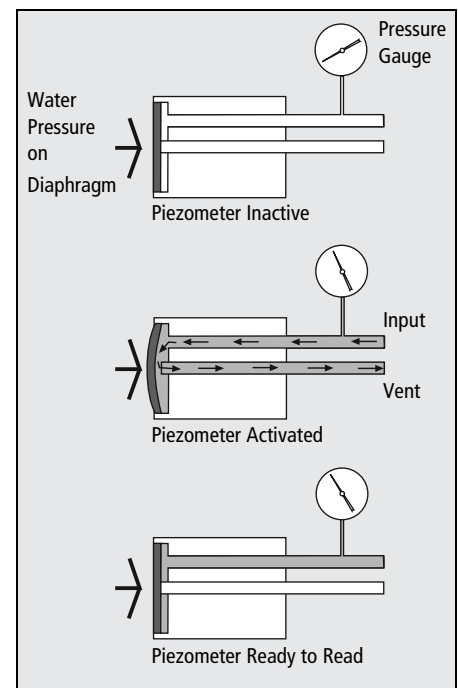
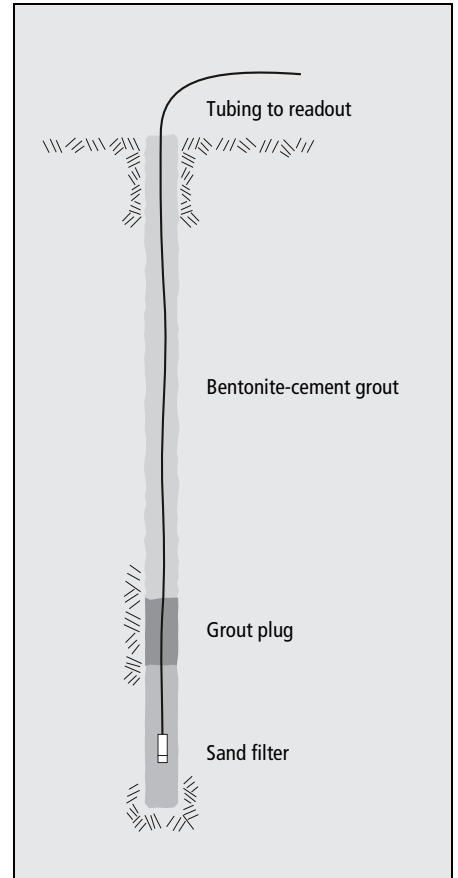

### Applications

Pneumatic piezometers are used to measure pore water pressure in saturated soils. Applications include:

- Monitoring pore pressures to determine safe rates of fill or excavation.
- Monitoring pore water pressures to determine slope stability.
- Monitoring the effects of dewatering systems used for excavations.
- Monitoring the effects of ground improvement systems such as vertical drains and sand drains.
- Monitoring pore water pressures to check the performance of earth fill dams and embankments.
- Monitoring pore water pressures to check containment systems at landfills and tailings dams.

### Advantages

Slope Indicator's pneumatic piezometers employ a simple and reliable transducer that is inherently free from drift.

Long term performance is enhanced by corrosion-resistant plastic construction, polyethylene tubing, and in-line filters in all connectors.

Twin-tube design is compatible with both "flow" and "no-flow" reading techniques.

### Operating Principle

In a typical installation, the piezometer is sealed in a borehole, embedded in fill, or suspended in a standpipe. Twin pneumatic tubes run from the piezometer to a terminal at the surface. Readings are obtained with a pneumatic indicator.

The piezometer contains a flexible diaphragm. Water pressure acts on one side of the diaphragm and gas pressure acts on the other.

When a reading is required, a pneumatic indicator is connected to the terminal or directly to the tubing. Compressed nitrogen gas from the indicator flows down the input tube to increase gas pressure on the diaphragm. When gas pressure exceeds water pressure, the diaphragm is forced away from the vent tube, allowing excess gas to escape via the vent tube.

When the return flow of gas is detected at the surface, the gas supply is shut off. Gas pressure in the piezometer decreases until water pressure forces the diaphragm to its original position, preventing further escape of gas through the vent tube.

At this point, gas pressure equals water pressure, and a reading can be obtained from the pressure gauge on the indicator.

**PNEUMATIC PIEZOMETER**

**Sensor Type:** Twin-tube pneumatic transducer.  
**Range:** Pressure rated for 27.5 bar or 400 psi. Working range depends on gauge supplied with pneumatic indicator. Digital gauge provides range to 690 kPa / 100 psi. Analog gauges provide ranges to 1000 kPa / 150 psi.  
**Repeatability:** ±0.25% FS.  
**Diaphragm Displacement:** 0.01 ml typical.  
**Filter:** Sintered stainless steel, 50 micron pores.  
**Materials:** ABS and PVC plastic body, synthetic rubber diaphragm.  
**Diameter:** 25.4 mm (1").

**PIEZOMETER ONLY**

**Pneumatic Piezometer . . . . . 51417800**  
 Part number includes piezometer and one quick connect plug. Tubing is attached to piezometer at factory and must be ordered at same time as piezometer.

**PIEZOMETER WITH TUBING**

**Piezometer & 50' of tubing . . . . . 51417801**  
**Piezometer & 100' of tubing . . . . . 51417802**  
**Piezometer & 150' of tubing . . . . . 51417803**  
**Piezometer & 200' of tubing . . . . . 51417804**  
 Order numbers specify a pneumatic piezometer with tubing and quick-connect plug. These piezometers are stocked for faster delivery.

**TUBING & CONNECTORS**

**Twin Tubing . . . . . 51416900**  
 Two polyethylene tubes bundled in polyethylene jacket.  
**Tubing Size:** 4.76 mm with 1 mm wall (3/16" with 0.04" wall).  
**Jacket:** 12 mm x 7 mm with 1.1 mm wall (0.46" x 0.28" with 0.045" wall).  
**Burst Pressure:** 3.4 MPa (500 psi).  
**Minimum Bending Radius:** 75 mm (3").  
**Tubing Buoyancy:** 0.021 kg per m (0.014 lb per foot).  
**Weight:** 0.06 kg per meter (0.04 lb per foot).  
**Splice Kit . . . . . 51401723**  
 Includes 3 brass unions, self-vulcanizing mastic pad, and sealing tape.  
**Quick Connect Plug . . . . . 51407302**  
 Brass quick-connect fitting for input tube. Plug includes in-line filter and 90° elbow for insertion into panel. One quick connect plug included with sensor.

**INSTALLATION ACCESSORIES**

**Small Canvas Bag . . . . . 06240000**  
**Large Canvas Bag . . . . . 06240001**  
 Creates a sand filter around piezometer. Also assists with sinking the piezometer in water-filled boreholes. Small bag is 64 x 457 mm (2.5 x 18"). Large bag is 114 x 457 mm (4.5 x 18").  
**Push-In Well Point . . . . . 51400099**  
 Steel well point for piezometer, 30 x 610 mm (1.25 x 24"), 2 kg (4.4 lb). This part number includes labor to insert piezometer into well point, but does not include piezometer, tubing, or quick-connect plug.

**TERMINALS**

**Terminal Pipe, 6 Positions . . . . . 51409900**  
 Heavy gauge, zinc-plated, iridium treated steel pipe, 70 mm x 2 m (2.75" x 80"). Inside panel accommodates quick connect plugs from 6 piezometers. Includes panel, panel nuts, locking cap, keyed-alike padlock, and 90° PVC sweep for tubing entry.  
**Terminal Pipe, 20 Positions. . . . . 51417100**  
 Heavy gauge, zinc plated steel pipe, 127 mm x 178 mm x 1.8 m (5" x 7" x 6'). Inside panel accommodates quick connect plugs from 20 piezometers. Includes panel and panel nuts, locking cap, keyed-alike padlock, and 90° PVC sweep for tubing entry.  
**Terminal Box, 10 Positions . . . . . 51401510**  
 Fiberglass box with lockable lid, 292 x 235 x 140 mm (11.5 X 9.25 x 5.5"). Inside panel accommodates quick connect fittings from 10 piezometers. Box can be mounted to wall or post. Includes panel and panel nuts.

**PNEUMATIC INDICATOR**

**With 0.25% Analog Gauge . . . . . 51425601**  
**With 0.1% Digital Gauge . . . . . 51425602**  
 See separate datasheet for details.