

Tape Extensometer

51811599

Copyright ©2008 Slope Indicator Company. All Rights Reserved.

This equipment should be installed, maintained, and operated by technically qualified personnel. Any errors or omissions in data, or the interpretation of data, are not the responsibility of Slope Indicator Company. The information herein is subject to change without notification.

This document contains information that is proprietary to Slope Indicator company and is subject to return upon request. It is transmitted for the sole purpose of aiding the transaction of business between Slope Indicator Company and the recipient. All information, data, designs, and drawings contained herein are proprietary to and the property of Slope Indicator Company, and may not be reproduced or copied in any form, by photocopy or any other means, including disclosure to outside parties, directly or indirectly, without permission in writing from Slope Indicator Company.

SLOPE INDICATOR

12123 Harbour Reach Drive
Mukilteo, Washington, USA, 98275
Tel: 425-493-6200 Fax: 425-493-6250
E-mail: solutions@slope.com
Website: www.slopeindicator.com

Contents

Introduction	1
Installing Reference Points.....	2
Taking Readings.....	7
Sample Field Data Sheet.....	12
Data Reduction	13
Testing and Maintenance.....	16
Appendix A	19

Introduction

- Tape Extensometer** The tape extensometer is used to monitor changes in the distance between two reference points.
- Steel Tape** A steel gaging tape is used to span the distance between the two reference points (with the body of the extensometer interposed). Markings on the tape are used to identify the index holes that are punched into the tape every 50 mm or 2 inches.
- The tape is about 165 mm or 6.5 inches shorter than its markings indicate, so it cannot be used as a surveyor's tape. Tape readings are eliminated in the calculation of changes, so the actual length of the tape is not relevant. Since absolute measurements are not required, it is not necessary to consider the tape catenary or the stickout of reference points.
- Hooks** The free end of the tape has a snap hook, which is attached to one reference point. The tape is then unreeled until the operator can attach the hook on the instrument body to a second reference point.
- Nose & Index Pin** The instrument nose has a slot for the tape. The operator slips the tape into the slot and engages the index pin in the appropriate index hole. This provides a positive hold on the tape so that it can be tensioned.
- Tension Collar & Tension Control Marks** The tension collar is rotated to apply tension to the tape. When the control marks are aligned, the tape is correctly tensioned.
- Digital Display** The digital display provides the measured readings.



Installing Reference Points

Overview Reference points are stainless steel eyebolts that are threaded into groutable or expansion anchors. Reference points may also be bolted to the structure.

Reference points are positioned to reveal the magnitude and direction of movements. The drawings below shows typical locations for reference points. Since each site has unique conditions, the pattern of your reference points may not resemble those illustrated.

The hook & eye bolt system can accommodate almost any angle of the tape. However, it is important to protect the points once they have been installed, since any change in the position or the condition of the points will affect the repeatability of the system.

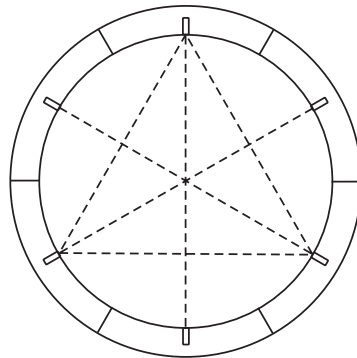

Reference points installed in pre-formed holes in concrete liner.

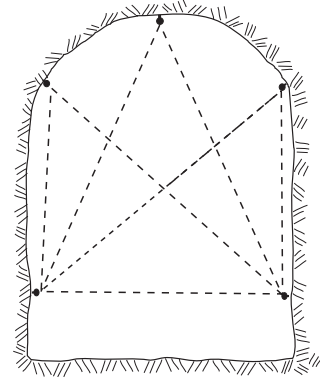

Reference points grouted into drill holes in rock.

Using Groutable Rebar Anchors in Rock or Concrete

- Parts required:
- Eyebolts (1/4-20 thread). Be sure to have a spare eyebolt for installation and testing of the anchor.
 - 7/16 inch lock nuts (1/4-20 thread).
 - Stud (1/4-20 thread).
 - Rebar anchor (length depends on competence of rock/concrete).
 - Non-shrinking grout. Or see next page for use of epoxy cartridges.

- Tools required:
- Rock drill and bit capable of drilling 3/4” or 1” diameter holes slightly deeper than the length of the rebar anchor.
 - Compressed air to clean hole.
 - 7/16” open-end wrench.
 - Adjustable wrench.

- Instructions
1. Select and mark locations for reference points.
 2. Drill 3/4” or 1” hole to depth approximately 1/2-inch deeper than length of anchor. Clean debris from hole with compressed air.
 3. Grout anchor in hole using a suitable mixture of non-shrinking, “under-water” grout. If necessary, pack the hole to prevent grout seepage.
 4. When the grout is hard, thread a spare eyebolt into the anchor and pull test the anchor to 30 lbf (max). If there is no measurable movement, the anchor is installed satisfactorily. Remove the spare eyebolt.
 5. Thread a lock nut onto the eyebolt, and then thread the eyebolt into the anchor. If it is difficult to turn the eyebolt, use an adjustable wrench (closed across the circle of the eyebolt) for additional leverage. Important: Do not use a screw driver for additional leverage, since any implement inserted though the eyebolt may deform the eyebolt and make it difficult to obtain repeatable readings in the future.
 6. Hold the eyebolt in position with the adjustable wrench (closed across the eyebolt circle) and tighten the lock nut with the 7/16” open-end wrench.

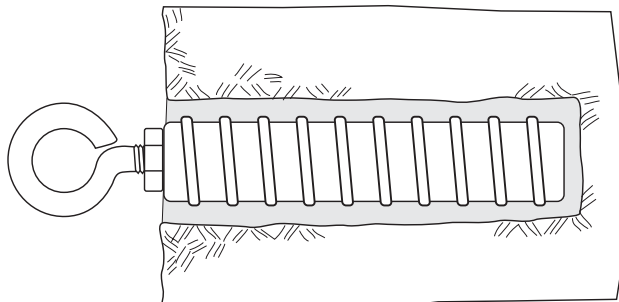

Using Glass Resin Cartridges and Rebar Anchors in Rock or Concrete

- Instructions
1. Select and mark locations for reference points.
 2. Drill 3/4" hole to depth specified by instructions for resin cartridge, then clean debris from hole using compressed air.
 3. Install resin cartridge and rebar anchor (chisel end first)
 4. Thread lock nut onto stud, and then thread stud into anchor. Spin anchor to mix resin. Be sure to spin at the rate specified by the manufacturer of the resin cartridge. To spin by hand, use 7/16" open-end wrench on the locknut. If the resin instructions permit, you may also use a drill motor to spin the anchor. Note: It may be necessary to pack the hole to prevent resin seepage or to centralize the anchor until the resin fully cures.
 5. When the resin is fully cured, remove the stud, and thread a spare eyebolt into the anchor. Then pull test the anchor to 30 lbf (max). If there is no measurable movement, the anchor is installed satisfactorily. Remove the spare eyebolt.
 6. Thread a lock nut onto the eyebolt, and then thread the eyebolt into the anchor. If it is difficult to turn the eyebolt, use an adjustable wrench (closed across the circle of the eyebolt) for additional leverage. Important: Do not use a screw driver for additional leverage, since any implement inserted through the eyebolt may deform the eyebolt and make it difficult to obtain repeatable readings in the future.
 7. Hold the eyebolt in position with the adjustable wrench (closed across the eyebolt circle) and tighten the lock nut with the 7/16" open-end wrench.

Using Expansion Anchors in Rock or Concrete

- Parts required:
- Eyebolts (1/4-20 thread). Be sure to have a spare eyebolt for installation and testing of the anchor.
 - 7/16 inch lock nuts (1/4-20 thread).
 - Expansion anchors.

- Tools required:
- Rock drill capable of drilling 4.5 inch deep, 1-3/8" diameter hole.
 - Compressed air for cleaning hole.
 - 7/16" and 3/4" open-end wrenches.
 - Adjustable wrench.

- Instructions
1. Select and mark locations for reference points.
 2. Drill holes 4.5 to 5" deep.
 3. Clean debris from hole using compressed air.
 4. Adjust expansion anchor to fit hole, then insert until setting bolt is slightly below rock face.
 5. Tighten anchor until refusal point.
 6. Thread spare eyebolt into expansion anchor. Pull test to 30 lbf (max). If there is no measurable movement, the anchor is installed satisfactorily. Remove spare eyebolt.
 7. Thread lock nut onto eyebolt, then thread eyebolt into the anchor. If it is difficult to turn the eyebolt, use an adjustable wrench (closed across the circle of the eyebolt) for additional leverage. Important: Do not insert a screw driver or any other implement through the eyebolt for leverage. This may deform the eyebolt and make it difficult to obtain repeatable readings in the future.
 8. Hold the eyebolt in position with the adjustable wrench (closed across the eyebolt circle) and tighten the lock nut with the 7/16" open-end wrench.

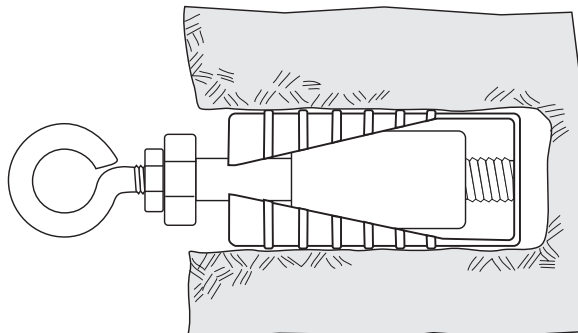

Installing Points on Steel Structural Members

- Parts required:
- Eyebolts (1/4-20 thread).
 - 7/16 inch lock nuts (1/4-20 thread).

- Tools required:
- Drill motor.
 - #7 drill (0.201”), high speed steel.
 - 1/4-20 tap and tap handle.
 - Adjustable wrench.
 - 7/16” open-end wrench.

- Instructions
1. Select and mark locations for reference points.
 2. Drill a hole into or through the steel member using the #7 (0.201”) drill.
 3. If the far side of the member is not accessible, tap the hole using a 1/4-20 tap.
 4. Thread the lock nut onto the eyebolt, and then thread the eyebolt into the tapped hole. If it is difficult to turn the eyebolt, use an adjustable wrench (closed across the circle of the eyebolt) for additional leverage. Important: Do not use a screw driver for additional leverage, since any implement inserted through the eyebolt may deform the eyebolt and make it difficult to obtain repeatable readings in the future.
 5. Hold the eyebolt in position with the adjustable wrench (closed across the eyebolt circle) and tighten the lock nut with the 7/16” open-end wrench.

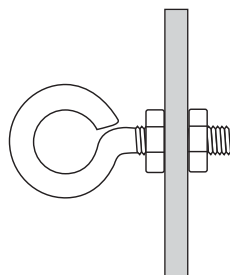

Taking Readings

Introduction

Measurements obtained with the tape extensometer are used to calculate changes in the distance between two reference points. It is not difficult to obtain good measurements, but you must follow a standard procedure. The basic procedure is given below, and then particular steps are explained in detail in the following pages.

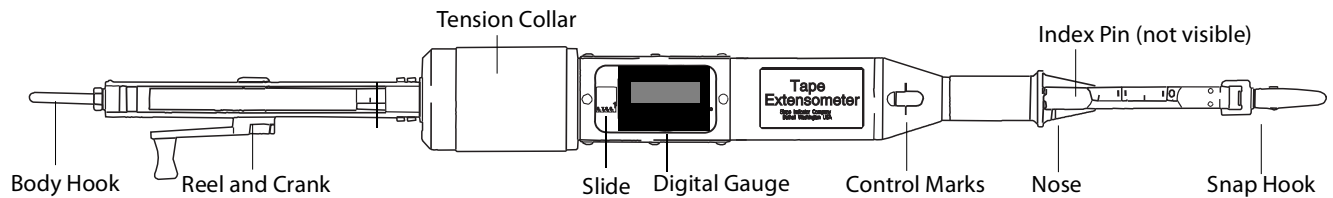

Hook the Tape To Reference Points

1. Check that the tape can be unreel. Remove the tape from the nose slot, if necessary. Flip the crank lever to the ready position.
2. Attach the snap hook to the first reference point. Then carry the instrument to the opposing reference point, allowing the tape to unreel as you walk. Hook the instrument body to this reference point.

Tension the Tape

1. Point the nose of the instrument directly at the opposing reference point. Pull on the tape, slide it into the nose slot, and engage the appropriate index hole with the index pin in the nose. Now the tape can be tensioned. See the detailed instructions for selecting an index hole.
2. Hold the body of the instrument loosely and rotate the tension collar until the tension control marks are aligned. Tensioning the tape properly is the key to accurate measurements. See the detailed instructions for tensioning the tape.

Obtain the Measurement

Once the tape has been tensioned, you can read the instrument. Add the value on the tape and reading from the display.

Remove Tape Tension and Retrieve the Tape

1. Rotate the tension collar to release the tension, then remove the tape from the nose slot.
2. Unhook the body, and walk toward the opposing reference point, winding up the tape as you go.

Selecting the Index Hole

If you look at the tape, you will see index holes punched every 50 mm or every 2 inches. Index holes work with the index pin in the instrument nose. When the pin is engaged in an index hole, the tape is held securely.

You must select an index hole at the time you make the initial measurement of a pair of reference points, and then you use that same index hole for all subsequent measurements of that pair of points. Here is the procedure for selecting an index hole:

1. Use the tension collar to set an initial position for the slide. If you are not sure of the direction of movement, rotate the tension collar until the slide is set mid-scale at 25 mm or 1 inch. If you expect only convergence, set the slide nearer to 50 mm or 2 inches. If you expect only extension, set it nearer to 0.
2. Attach the instrument between the two reference points. Slide the tape into the instrument nose and fit the index pin into the nearest index hole. Choose the hole that makes the tape as tight as possible. This will give you the maximum measurement range before you have to switch to the next index hole.
3. Tension the tape as explained on the next page. The slide moves as you rotate the tensioning collar, and some of the measurement range is lost. If you lose more than half of the measurement range, you should try a different index hole. Rotate the collar to remove tension from the tape, and start from step 1 again.
4. When you have found the proper index hole, read the tape marks at that hole and note the reading on your field data sheet. You will use this index hole every time you take a measurement of these two points.

Switching Index Holes

As convergence or extension continues, the slide will come very close to the low or high end of its range. At this point, you should obtain two repeatable measurements, one measurement from the current index hole and a second measurement from the next index hole. To make the second measurement, you must rotate the tension collar to move the slide to the other end of its range.

When you compare the two readings, you may find a slight offset, but it is not necessary to think about the offset when you are obtaining readings. The chapter on data reduction tells what to do with the offset.

Tensioning the Tape

To tension the tape, rotate the tension collar to align the tension control marks.

- The top drawing at right shows a tape that is not tensioned.
- The middle drawing shows a tape that is over-tensioned.
- The bottom drawing shows control marks that are aligned, indicating proper tension.

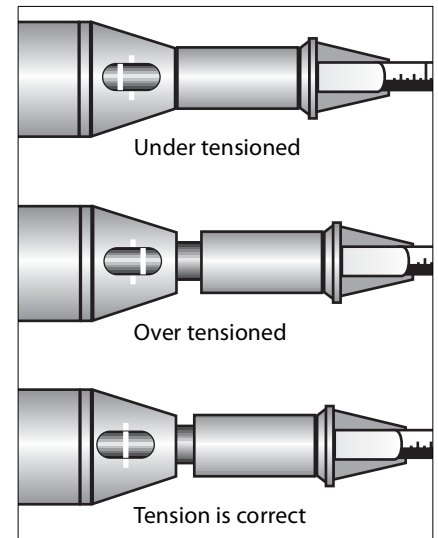

Procedure

1. Engage the index pin in the appropriate index hole. Support the instrument with one hand, and point the nose of the instrument directly at the opposing reference point.
2. Rotate the tension collar to adjust the tension. The readings on the display will increase with tension.
3. As you make fine adjustments, move the nose of the instrument up and down slightly, as shown in the drawing below. This eliminates hysteresis and helps you find a repeatable tension. Watch the control marks:
 - When the nose points directly at the reference point, the marks should be aligned.
 - When the nose does not point directly at the reference point, the control marks should show over-tension.
 - The control marks must not show under-tension in any position.
4. When the control marks are aligned, the instrument is ready to read.

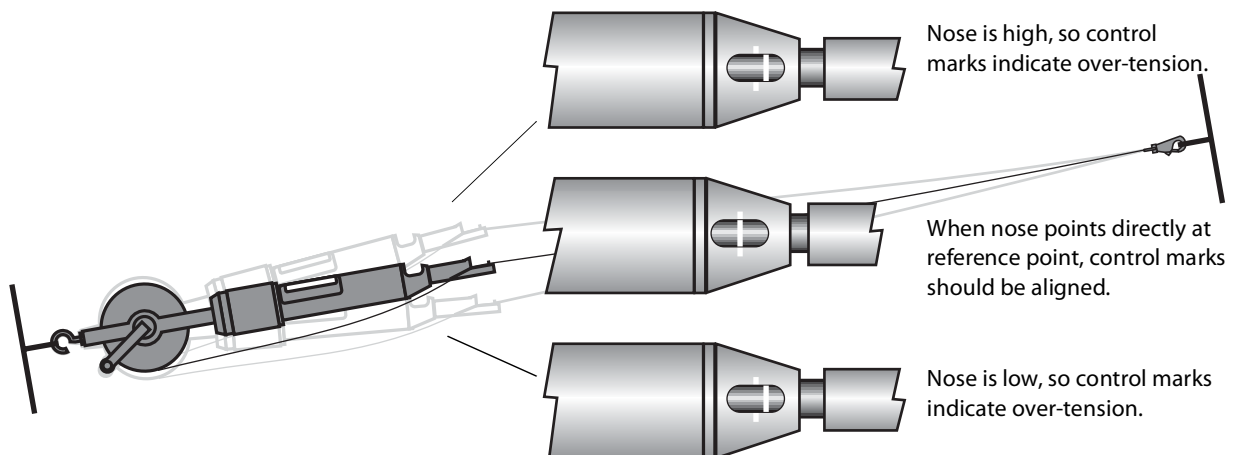

Reading the Steel Gaging Tape

The steel tape may have english units on one side and metric units on the other side. The units visible at the index hole when the tape is installed on the pin will dictate the reading units for the system.

English: The english tape is marked in inches. Each marking has 2 digits, indicating feet then inches. For example, a marking of 3-6 indicates 3'6". Measurements to 0.001" are provided by the digital display.

Metric: The metric tape is marked in centimeters. Each index hole will have a mark for meters with a measurement in centimeters below it. Millimeters are read from the digital display.

Reading the Digital Display

After the tape is tensioned, look in the window to obtain readings from the digital display.



Collecting Data

The sample data sheet on the next page provides the following fields:

Project: Enter the name of the project.

Initial Reading: Enter the date of the initial reading.

Station: Enter the ID for the reading station.

Instrument Serial: Enter the serial number of the tape extensometer.

Reference Points: Enter the ID for the pair of reference points.

Date: Enter the measurement date.

Operator: Enter the operator's initials.

Tape: Read the tape at the selected index hole and enter the value here.

Display: Enter the reading from the digital display.

Metric Example:

Tape	Display
12 m 35 cm	15.43 mm

English Example:

Tape	Display
26 ft 3 in	0.045

Other Data

If you have a suitable thermometer, it is sometimes useful to collect temperature data, so that you can correlate movement with temperature changes. However, it is not generally necessary to collect temperature data for the purpose of calculating temperature corrections unless the site is experiencing extreme shifts of temperature.

Data Reduction

Using the Data Sheet

For each pair of reference points you have two data values: the tape reading at the index hole and the reading from the display. Here are two examples:

Metric Example

The display shows 15.43 mm. Add the tape reading to arrive at a sum of 12365.43 mm.

Tape	Display	Sum
12.35 m	15.43	12365.43 mm

English Example

The display shows 0.045 inches. Add the tape reading to arrive at a sum of 315.045 inches.

Tape	Display	Sum
26 ft 2 in	0.045 in	314.045 in

Calculating Changes

To calculate the change, subtract the initial reading from the current reading. This example shows 0.17 mm of convergence.

Current	- Initial	= Change
12365.43 mm	12365.60 mm	- 0.17 mm

- A negative number indicates convergence.
- A positive number indicates extension.

Index Holes and Offsets

As convergence or extension progresses, the shaft within the tape extensometer body eventually reaches the high or low limit of its range. At this point, the operator must switch to a new index hole, so subsequent measurements may contain a small offset. The procedure below tells how to calculate the offset and what to do with it.

1. When it is necessary to switch to a new index hole, obtain two measurements, one from the original index hole, and a second from the new index hole.
2. Calculate the change value for both readings, following the usual convention (current - initial).

	Current	- Initial	= Change
Original Index Hole	12373.25 mm	12423.25 mm	-50.00 mm
New Index Hole	12373.37 mm	12423.25 mm	-50.12 mm

3. In theory, the change values should be the same. In practice, there is usually a slight offset. Calculate the offset by subtracting the "original" from the "new" change.

New	- Original	= Offset
-50.12 mm	-50.00 mm	-0.12 mm

4. This offset should now be a part of every change calculation made for measurements taken at the new index hole. The offset is subtracted from the change, as shown below.

current	- Initial	= Change	- Offset	= Corrected Change
12373.37 mm	12423.25 mm	-50.12 mm	- (-0.12 mm)	-50 mm

Temperature Effects

This page is included for completeness. Temperature effects on the tape, body, and spring are quite small. Unless your site has extreme changes in temperature, it may not be useful to calculate and apply the corrections below.

Coefficient of Expansion

The tape lengthens in higher temperatures and shortens in lower temperatures.

- Steel Tape: 11.6×10^{-6} ppm/ °C (6.45×10^{-6} ppm/ °F).
- Aluminum Body: 23×10^{-6} ppm/ °C (12.8×10^{-6} ppm/ °F).

The steps below show how to make temperature corrections for the tape. If required, temperature corrections can also be applied to the length of the instrument body, which is 610 mm or 24 inches long.

Making Temperature Corrections

1. Calculate the change in length of the tape due to temperature:

$$\Delta\text{Length} = \text{Tape Length} \times \text{Temperature Coefficient} \times \Delta\text{Temperature}$$

ΔLength is the change in the length of the tape due to temperature.

Tape Length is the summed reading.

Temperature coefficient is either English or Metric.

$\Delta\text{Temperature}$ is the change in temperature: $T_{\text{current}} - T_{\text{initial}}$

2. Find the corrected length of the tape by adding the change in length.

$$\text{Corrected Tape Length} = \text{Tape Length} + \Delta\text{Length}.$$

Example

This example ignores temperature effects on the body.

- Tape length is 11.4 m.
- $\Delta\text{Temperature}$ is 10 degrees C.
- Metric temperature coefficient is 11.6×10^{-6} per degree C.

1. Calculate ΔLength

$$\begin{aligned}\Delta\text{Length} &= \text{Tape Length} \times \text{Temperature Coefficient} \times \Delta\text{Temperature} \\ &= 11.4 \text{ m} \times 11.6 \text{ E-6} \times 10 \\ &= 0.0013 \text{ m}\end{aligned}$$

2. Calculate the corrected tape length.

$$\begin{aligned}\text{Corrected Tape Length} &= \text{Tape Length} + \Delta\text{Length}. \\ &= 11.4 \text{ m} + 0.0013 \\ &= 11.4013 \text{ m}\end{aligned}$$

Testing and Maintenance

Testing The tests described below can be used for acceptance tests as well as for regular evaluations of the condition of the instrument.

Measurement Test Test the instrument by taking readings between two reference points that are known to be stable. It may be convenient to construct a rigid steel frame for this purpose. The frame should be designed such that the measurement can be made with the instrument in the vertical attitude so tape catenary (sag) is not a factor.

Make the initial test when you receive the instrument. The frequency of subsequent tests depends on the use and abuse the instrument is subjected to. Always include temperature readings with the test data. Measurements should repeat within 0.005in or 0.15mm. Note that the measurement is not the absolute distance between the two reference points.

Load Test The load test checks the performance of the spring that applies a tension load to the tape.

Hang the instrument vertically, so that the nose points down. Suspend a weight from the instrument nose. Tap the instrument to overcome any friction. The index marks should align.

Note #1: Refer to the instrument calibration sheet for the proper weight.

Note #2: If you suspend the weight from the snap hook on the tape, rather than directly from the instrument nose, be sure that there is slack between the tape reel and the nose, so that the tape does not interfere with the load test.

General Maintenance

The tape extensometer requires very little maintenance, apart from changing the battery, keeping it clean, and following the suggestions below.

Changing the Battery

The digital readout uses a SR44, silver oxide (or equivalent) battery.

1. Slide battery cover forward (in direction of arrow).

2. Install battery with plus side facing up.

3. There will be an arbitrary value displayed on your readout. You will need to re-establish the origin.

- Twist tension collar until shaft approaches side of display.
- Gently hold tension collar at knurled end.
- Tighten collar until shaft comes in contact with digital display.
- **DO NOT FORCE SHAFT INTO SIDE OF DISPLAY.**
- Hold down the ORIGIN button for more than one second. The readout will display "0.00".



Tension Collar

Do not lubricate the threads of the tension collar. A high quality lubricant was applied at the factory. Other lubricants may dilute the factory applied lubricant or wash dirt or grit into the thread.

Steel Tape

Treat the steel tape as you would any other precision surveying tape. To inhibit corrosion, periodically apply oil to the steel tape and wipe clean. To smooth the operation of the tape crank mechanism, lubricate it with powdered graphite.

Lock Nut & Hook

A loose lock nut may allow the hook at the end of the instrument to change position, resulting in a zero shift. Follow the steps below to reposition the hook.

1. Hold the hook in position with an adjustable wrench closed across the hook circle. Tighten the lock nut with a 7/16" open-end wrench.
2. Perform the measurement test described in this chapter to check for zero shift.
3. If necessary, loosen the lock nut and rotate the hook a half turn (either direction) and tighten the lock nut again.
4. Repeat the measurement test. Continue the adjustment process until the hook has returned to its original position.

Replacing the Tape

Replacement tapes can be ordered from Slope Indicator. The tape is supplied on a hub inside a bracket. You can replace just the tape or you can replace the entire assembly.

Be sure to indicate on the field data sheet that you have changed tapes, because a new tape will most likely cause a shift in readings. This shift cannot be overcome by a measurement test and adjustment of the hook because the holes punched in the tape will not be in exactly the same position.

You can determine the offset for particular holes by comparing new and old readings at stable reference points.

Replacing Tape Only

1. Remove crank: hold the hub and turn the crank counter-clockwise.
2. Remove tape: Slowly push the tape and hub out of the bracket. There is a spring washer on top of the hub. Remember its orientation.
3. Remove replacement tape from bracket following instructions above.
4. Slip replacement tape, hub, and spring washer into the bracket. Check the orientation of the washer. Its flat center portion should fit against the hub and its curved up edges should press against the reel assembly. Also, the free end of the tape should exit the reel on the underside of the instrument.
5. Hold the hub and replace the crank, rotating it clockwise. Do not over-tighten.

Replacing Entire Reel

This requires a $7/64$ inch hex wrench and a $7/16$ inch open-end wrench. You will replace the bracket as well as the tape.

1. Screw the tension collar all the way in (toward the nose of the instrument) until it stops. Do not use force.
2. Mark the top of the square block that the bracket attached to.
3. Remove the six hex head screws and remove the tape bracket.
4. Attach new bracket and tape, paying attention to the orientation of the square block. (Free end of tape should point downwards).
5. Replace screws, but do not over-tighten them. A little thread locking-compound can be useful to keep screws in place.
6. Remove the hook (for the reference point) from the old bracket and attach it to the new bracket.

Appendix A

- Digital Display**
- ON/OFF:** Turn display on and off.
 - ZERO/ABS:** The origin or zero reference is set at the factory. Pressing the zero/abs button will reset the zero reference to the current location of the shaft. This is indicated by the letters 'INC' in the top left corner of the display. Press and hold button to remove zero reference. Reading will return to its absolute value from the origin.
 - ORIGIN:** Replacing the battery in the display will alter the origin. See page 19 for detailed instructions on how to reset the origin.
 - in/mm:** The digital gauge can be toggled between inches and millimeters. Be sure that the units displayed correspond to the english or metric units read from the steel tape.
- Error Codes**
- This section describes possible error codes on the display. Consult factory for further trouble-shooting.
- ErrC and display flickering:** Appears when the scale surface is contaminated. The surface of the scale should be cleaned and a light film of low viscosity oil should be applied to repel water.
 - "E" as the last digit:** Appears if the readout is moved at a high speed. This does not affect measurement results. NOTE: If "E" is displayed when the unit is not being moved, the indicator is in the same state as that of ErrC. Use the ErrC remedy.
 - "B" Indicator:** Appears when the battery voltage is low. Immediately replace the battery. See Maintenance section for complete details on replacing the battery.